

3.3 V/5 V, 20 Mbit/sec, Logic Gate Optocoupler in Stretched Body SOP 6-Pin

FOD8173, FOD8173T

Description

The FOD8173 series packaged in a stretched body 6-pin small outline plastic package, consists of an aluminum gallium arsenide (AlGaAs) light emitting diode and a CMOS detector IC comprises an integrated photodiode, a high speed transimpedance amplifier and a voltage comparator with a totem-pole output driver. The electrical and switching characteristics are guaranteed over the extended industrial temperature range of -40 °C to 100 °C and a V_{DD} range of 3 V to 5.5 V.

Features

- FOD8173T – 8 mm Creepage and Clearance Distance, and 0.4 mm insulation distance to achieve reliable and high voltage insulation
- High Noise Immunity characterized by common mode transient immunity (CMTI)
- 20 kV/μs Minimum CMTI
- 3.3 V and 5 V CMOS Compatibility
- Specifications Guaranteed Over 3 V to 5.5 V supply voltage and -40 to 100 °C extended industrial temperature range
- High Speed
 - ◆ 20 Mbit/sec Data Rate (NRZ)
 - ◆ 55 ns max. Propagation Delay
 - ◆ 20 ns max. Pulse Width Distortion
- Safety and regulatory pending approvals
 - ◆ UL1577, 5,000 VAC_{RMS} for 1 min.
 - ◆ DIN-EN/IEC60747-5-5, 1,140 V peak working insulation voltage for FOD8173T

Typical Applications

- Microprocessor System Interface
 - ◆ SPI, I2C
- Industrial Field Bus Communications
 - ◆ DeviceNet, CAN, RS485
- Programmable Logic Control
- Isolated Data Acquisition System
- Voltage Level Translator

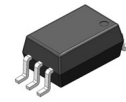

SOIC6
CASE 751EL

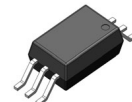

SOIC6 W
CASE 751EM

MARKING DIAGRAM

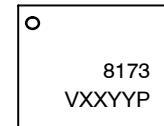

- 8173 = Device Number
- V = DIN EN/IEC60747-5-5 Option
- XX = Two Digit Year Code
- YY = Digit Work Week
- P = Assembly Package Code

PIN CONNECTIONS

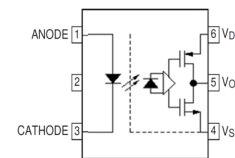

TRUTH TABLE

LED	V _O
Off	High
On	Low

ORDERING INFORMATION

See detailed ordering and shipping information on page 9 of this data sheet.

NOTE: Some of the devices on this data sheet have been **DISCONTINUED**. Please refer to the table on page 9.

FOD8173, FOD8173T

SAFETY AND INSULATIONS RATING

As per DIN EN/IEC 60747-5-5, this optocoupler is suitable for “safe electrical insulation” only within the safety limit data. Compliance with the safety ratings shall be ensured by means of protective circuits.

Table 1.

Parameter		Characteristics	
		FOD8173	FOD8173T
Installation Classifications per DIN VDE 0110/1.89 Table 1, For Rated mains Voltage	< 150 VRMS	I-IV	I-IV
	< 300 VRMS	I-IV	I-IV
	< 450 VRMS	I-III	I-IV
	< 600 VRMS	I-III	I-III
Climatic Classification		40/100/21	40/100/21
Pollution Degree (DIN VDE 0110/1.89)		2	2
Comparative Tracking Index		175	175

Table 2.

Symbol	Parameter	Characteristics		Unit
		FOD8173	FOD8173T	
V _{PR}	Input-to-Output Test Voltage, Method B, VIORM x 1.875 = VPR, 100% Production Test with tm = 1 s, Partial Discharge < 5 pC	1,671	2,137	Vpeak
	Input-to-Output Test Voltage, Method A, VIORM x 1.6 = VPR, Type and Sample Test with tm = 10 s, Partial Discharge < 5 pC	1,426	1,824	Vpeak
VIORM	Maximum Working Insulation Voltage	891	1,140	Vpeak
V _{IOTM}	Highest Allowable Over-Voltage	6,000	8,000	Vpeak
	External Creepage	≥ 8.0	≥ 8.0	mm
	External Clearance	≥ 7.0	≥ 8.0	mm
DTI	Distance Through Insulation (Insulation Thickness)	≥ 0.4	≥ 0.4	mm
T _S I _{S,INPUT} P _{S,OUTPUT}	Safety Limit Values – Maximum Values Allowed in the Event of a Failure,			
	Case Temperature	150	150	°C
	Input Current	200	200	mA
	Output Power	300	300	mW
R _{IO}	Insulation Resistance at T _S , V _{IO} = 500 V	>10 ⁹	>10 ⁹	Ω

FOD8173, FOD8173T

Table 3. ABSOLUTE MAXIMUM RATINGS ($T_A = 25\text{ }^\circ\text{C}$ unless otherwise specified)

Symbol	Parameter	Value	Unit
T_{STG}	Storage Temperature	-40 to +125	$^\circ\text{C}$
T_{OPR}	Operating Temperature	-40 to +100	$^\circ\text{C}$
T_J	Junction Temperature	-40 to +125	$^\circ\text{C}$
T_{SOL}	Lead Solder Temperature (Refer to Reflow Temperature Profile)	260 for 10sec	$^\circ\text{C}$
Input Characteristics			
I_F	Average Forward Input Current	20	mA
V_R	Reverse Input Voltage	5.0	V
P_{DI}	Input Power Dissipation (Note 1)	40	mW
Output Characteristics			
V_{DD}	Supply Voltage	0 to 6.0	V
V_O	Output Voltage	-0.5 to $V_{DD} + 0.5$	V
I_O	Average Output Current	10	mA
P_{DO}	Output Power Dissipation (Note 1)	70	mW

Stresses exceeding those listed in the Maximum Ratings table may damage the device. If any of these limits are exceeded, device functionality should not be assumed, damage may occur and reliability may be affected.

RECOMMENDED OPERATING CONDITIONS

The Recommended Operating Conditions table defines the conditions for actual device operation. Recommended operating conditions are specified to ensure optimal performance to the data sheet specifications. **onsemi** does not recommend exceeding them or designing to Absolute Maximum Ratings.

Table 4.

Symbol	Parameter	Min	Max	Unit
T_A	Ambient Operating Temperature	-40	+100	$^\circ\text{C}$
V_{DD}	Supply Voltages (Note 2)	3.0	5.5	V
V_{FL}	Logic Low Input Voltage	0	0.8	V
I_{OL}	Logic Low Output Current	0	7	mA
I_{FH}	Logic High Input Current	5.0	16	mA

Functional operation above the stresses listed in the Recommended Operating Ranges is not implied. Extended exposure to stresses beyond the Recommended Operating Ranges limits may affect device reliability.

Table 5. ISOLATION CHARACTERISTICS

(Apply over all recommended conditions, typical value is measured at $T_A = 25\text{ }^\circ\text{C}$)

Symbol	Parameter	Conditions	Min	Typ	Max	Unit
V_{ISO}	Input-Output Isolation Voltage	$T_A = 25\text{ }^\circ\text{C}$, R.H. < 50%, $t = 1.0\text{ min}$, $I_{I-O} \leq 20\text{ }\mu\text{A}$ (Notes 3, 4)	5,000			V_{ACRMS}
R_{ISO}	Isolation Resistance	$V_{I-O} = 500\text{ V}$ (Note 3)		10^{11}		Ω
C_{ISO}	Isolation Capacitance	$V_{I-O} = 0\text{ V}$, freq=1.0 MHz (Note 3)		1.0		pF

1. No derating required to 100 $^\circ\text{C}$.
2. 0.1 μF bypass capacitor must be connected between 4 and 6.
3. Device is considered a two terminal device: Pins 1, 2 and 3 are shorted together and Pins 4, 5, and 6 are shorted together.
4. 5,000 V_{ACRMS} for 1 minute duration is equivalent to 6,000 V_{ACRMS} for 1 second duration.

FOD8173, FOD8173T

Table 6. ELECTRICAL CHARACTERISTICS

(Apply over all recommended conditions, $T_A = -40\text{ }^{\circ}\text{C}$ to $+100\text{ }^{\circ}\text{C}$, $3.0\text{V} \leq V_{DD} \leq 5.5\text{V}$, unless otherwise specified. Typical value is measured at $T_A = 25\text{ }^{\circ}\text{C}$ and $V_{DD} = 3.3\text{V}$.)

Symbol	Parameter	Conditions	Min	Typ	Max	Unit
INPUT CHARACTERISTICS						
V_F	Forward Voltage	$I_F = 10\text{ mA}$	1.0	1.35	1.80	V
BV_R	Input Reverse Breakdown Voltage	$I_R = 10\text{ }\mu\text{A}$	5.0	18		V
I_{FHL}	Threshold Input Current			2.8	5.0	mA
OUTPUT CHARACTERISTICS						
V_{OL}	Logic Low Output Voltage	$I_O = 20\text{ }\mu\text{A}$, $I_F = 10\text{ mA}$		0.0027	0.01	V
		$I_O = 4\text{ mA}$, $I_F = 10\text{ mA}$		0.27	0.8	
V_{OH}	Logic High Output Voltage	$V_{DD} = 3.3\text{ V}$, $I_O = -20\text{ }\mu\text{A}$, $I_F = 0\text{ mA}$	$V_{DD} - 0.1$	3.3		V
		$V_{DD} = 3.3\text{ V}$, $I_O = -4\text{ mA}$, $I_F = 0\text{ mA}$	$V_{DD} - 0.5$	3.1		
		$V_{DD} = 5.0\text{ V}$, $I_O = -20\text{ }\mu\text{A}$, $I_F = 0\text{ mA}$	$V_{DD} - 0.1$	5.0		
		$V_{DD} = 5.0\text{ V}$, $I_O = -4\text{ mA}$, $I_F = 0\text{ mA}$	$V_{DD} - 0.5$	4.9		
I_{DDL}	Logic Low Output Supply Current	$I_F = 10\text{ mA}$, $V_{DD} = 3.3\text{ V}$		3.3	4.8	mA
		$I_F = 10\text{ mA}$, $V_{DD} = 5.0\text{ V}$		4.0	5.0	
I_{DDH}	Logic High Output Supply Current	$I_F = 0\text{ mA}$, $V_{DD} = 3.3\text{ V}$		3.3	4.8	mA
		$I_F = 0\text{ mA}$, $V_{DD} = 5.0\text{ V}$		4.0	5.0	

Product parametric performance is indicated in the Electrical Characteristics for the listed test conditions, unless otherwise noted. Product performance may not be indicated by the Electrical Characteristics if operated under different conditions.

Table 7. SWITCHING CHARACTERISTICS

(Apply over all recommended conditions, $T_A = -40\text{ }^{\circ}\text{C}$ to $+100\text{ }^{\circ}\text{C}$, $3.0\text{V} \leq V_{DD} \leq 5.5\text{ V}$, $I_F = 5\text{ mA}$), unless otherwise specified. Typical value is measured at $T_A = 25\text{ }^{\circ}\text{C}$ and $V_{DD} = 3.3\text{ V}$.)

Symbol	Parameter	Conditions	Min	Typ	Max	Unit
Date Rate (Note 5)					20	Mbit/sec
t_{PW}	Pulse Width		50			ns
t_{PHL}	Propagation Delay Time to Logic Low Output	$C_L = 15\text{ pF}$		25	55	ns
t_{PLH}	Propagation Delay Time to Logic High Output	$C_L = 15\text{ pF}$		25	55	ns
PWD	Pulse Width Distortion, $ t_{PHL} - t_{PLH} $	$C_L = 15\text{ pF}$		5.5	20	ns
t_R	Output Rise Time (10% – 90%)	$C_L = 15\text{ pF}$		7.0		ns
t_F	Output Fall Time (90% – 10%)	$C_L = 15\text{ pF}$		7.0		ns
$ CM_H $	Common Mode Transient Immunity at Output High	$I_F = 0\text{ mA}$, $V_O > 0.8 V_{DD}$, $V_{CM} = 1000\text{ V}$, $T_A = 25\text{ }^{\circ}\text{C}$ (Note 6)	20	40		kV/ μs
$ CM_L $	Common Mode Transient Immunity at Output Low	$I_F = 5\text{ mA}$, $V_O < 0.8\text{ V}$, $V_{CM} = 1000\text{ V}$, $T_A = 25\text{ }^{\circ}\text{C}$ (Note 6)	20	40		kV/ μs

5. Data rate is based on 10 MHz, 50% NRZ pattern with a 50 ns minimum bit time.

6. Common mode transient immunity at output high is the maximum tolerable positive dV_{cm}/dt on the leading edge of the common mode impulse signal, V_{cm} , to assure that the output will remain high. Common mode transient immunity at output low is the maximum tolerable negative dV_{cm}/dt on the trailing edge of the common pulse signal, V_{cm} , to assure that the output will remain low.

TYPICAL CHARACTERISTICS

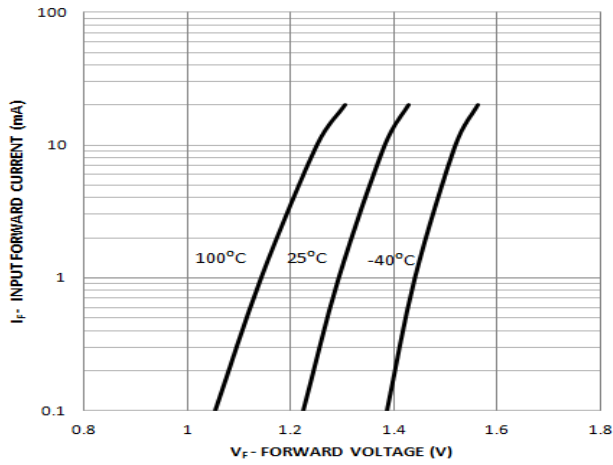

Figure 1. Input Forward Current vs. Forward Voltage

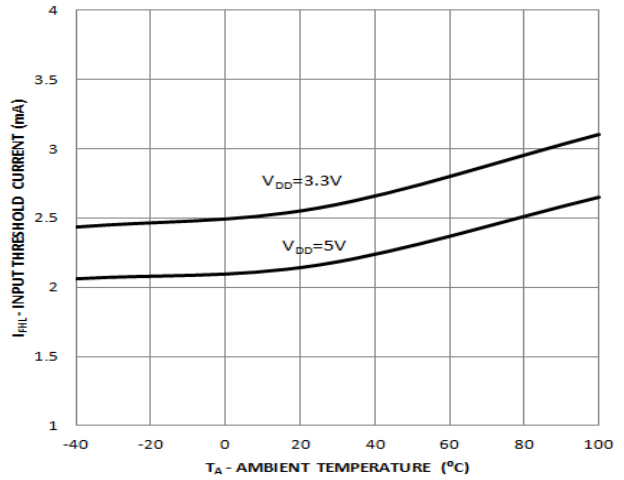

Figure 2. Input Threshold Current vs. Ambient Temperature

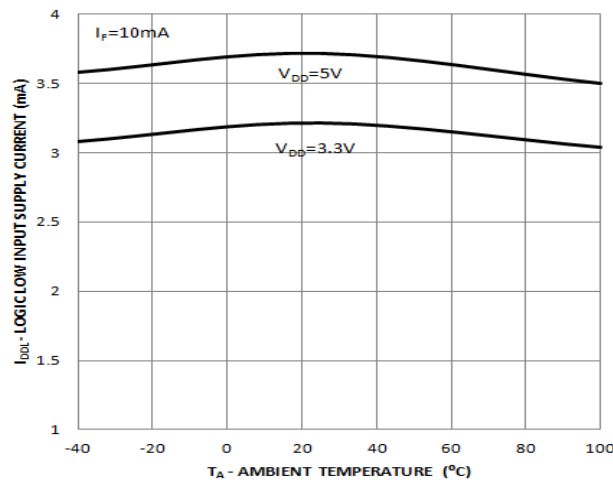

Figure 3. Logic Low Input Supply Current vs. Ambient Temperature

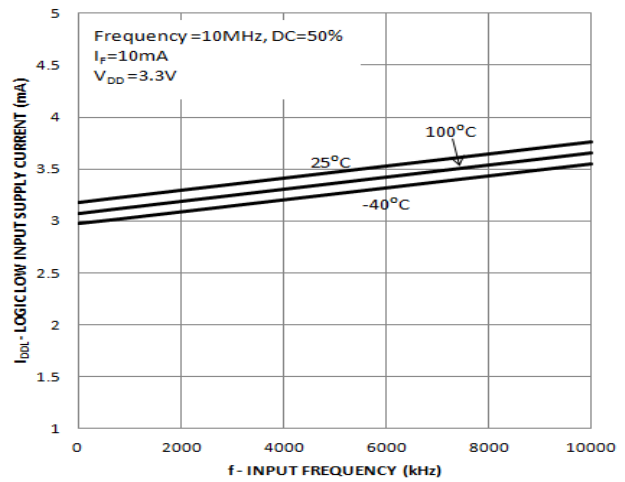

Figure 4. Logic Low Input Supply Current vs. Input Frequency ($V_{DD} = 3.3 V$)

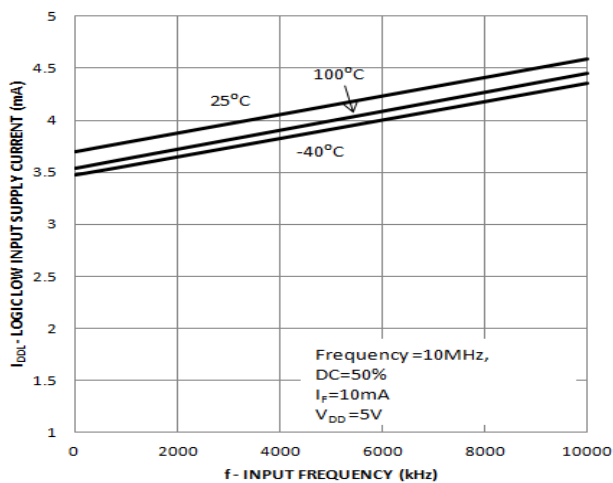

Figure 5. Logic Low Input Supply Current vs. Input Frequency ($V_{DD} = 5 V$)

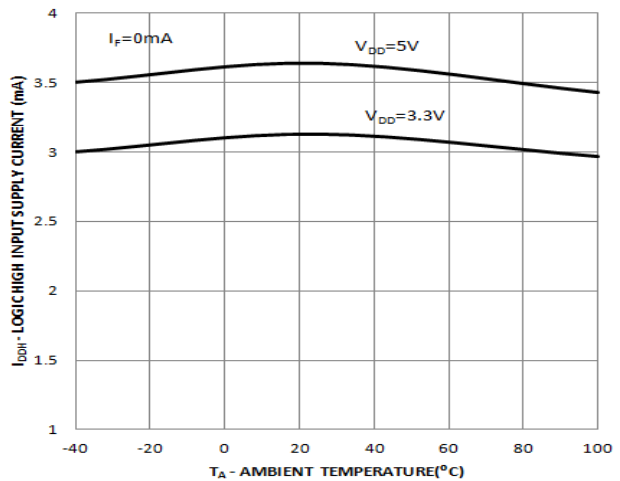

Figure 6. Logic High Input Supply Current vs. Ambient Temperature

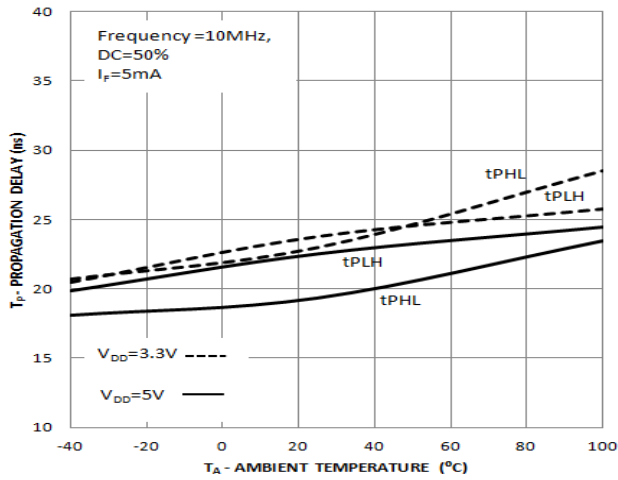

Figure 7. Propagation Delay vs. Ambient Temperature

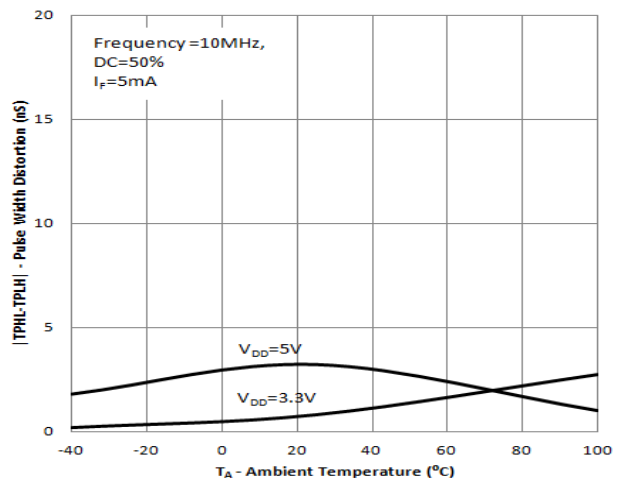

Figure 8. Pulse Width Distortion vs. Ambient Temperature

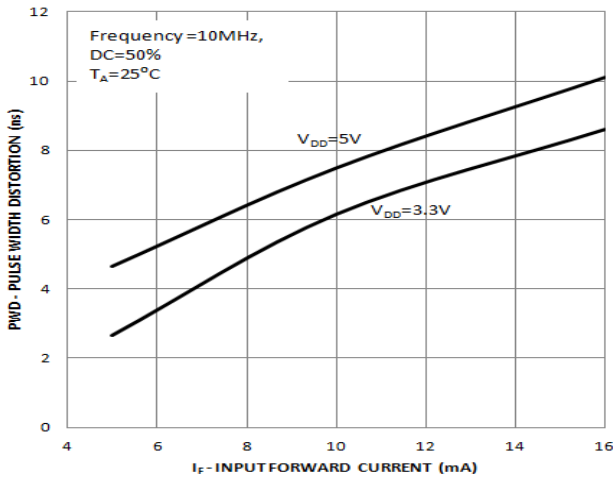

Figure 9. Pulse Width Distortion vs. Input Forward Current

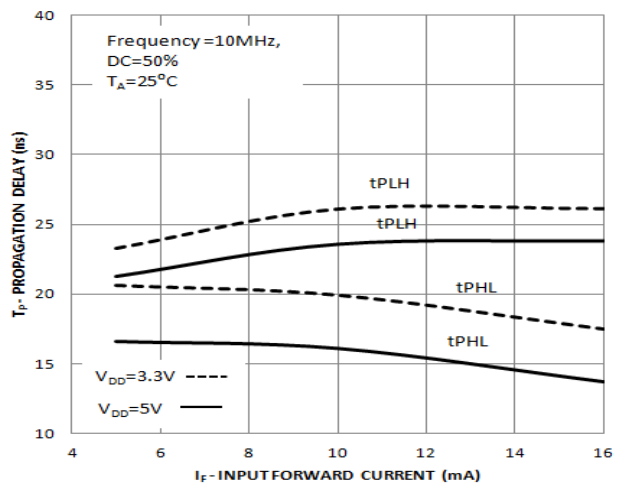

Figure 10. Propagation Delay vs. Input Forward Current

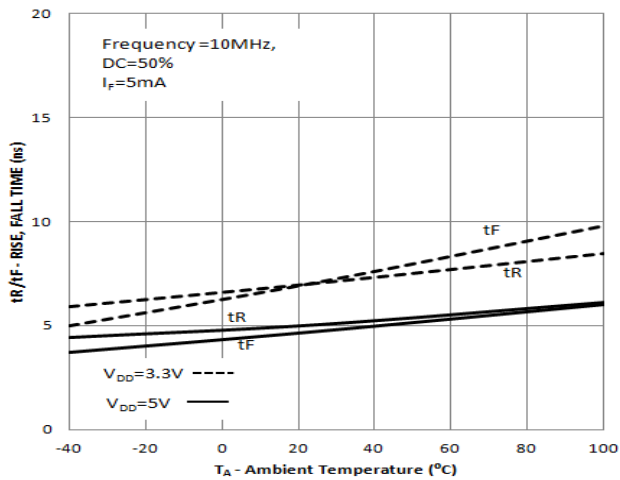

Figure 11. Rise, Fall Time vs. Ambient Temperature

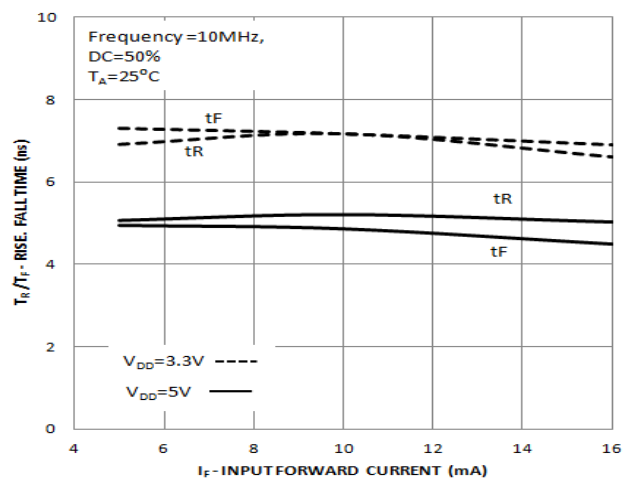

Figure 12. Rise, Fall Time vs. Input Forward Current

FOD8173, FOD8173T

SCHEMATICS

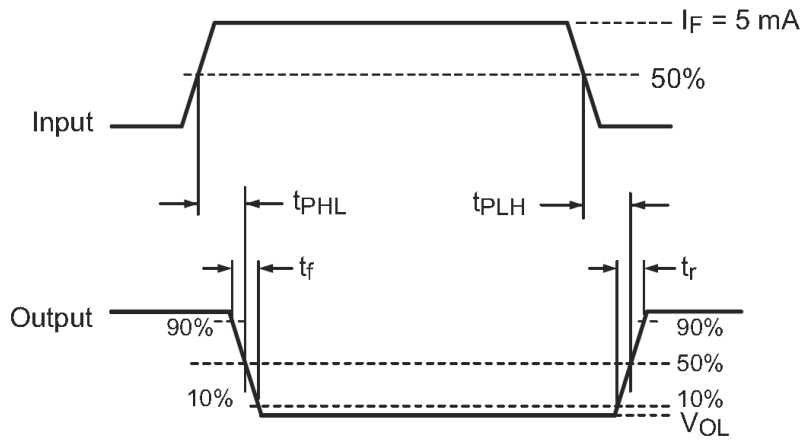
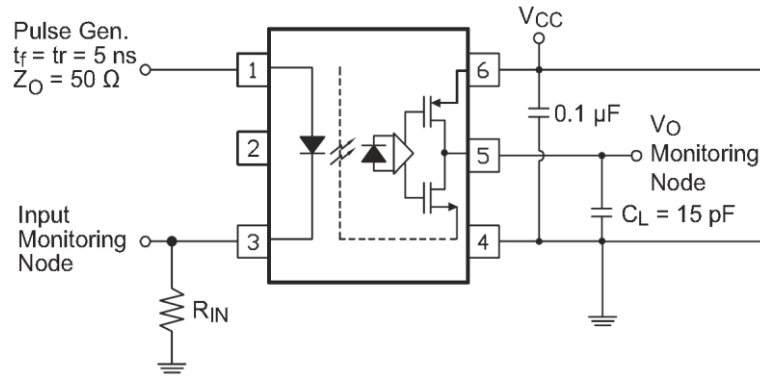

Figure 13. Test Circuit for Propagation Delay Time, Rise Time and Fall Time

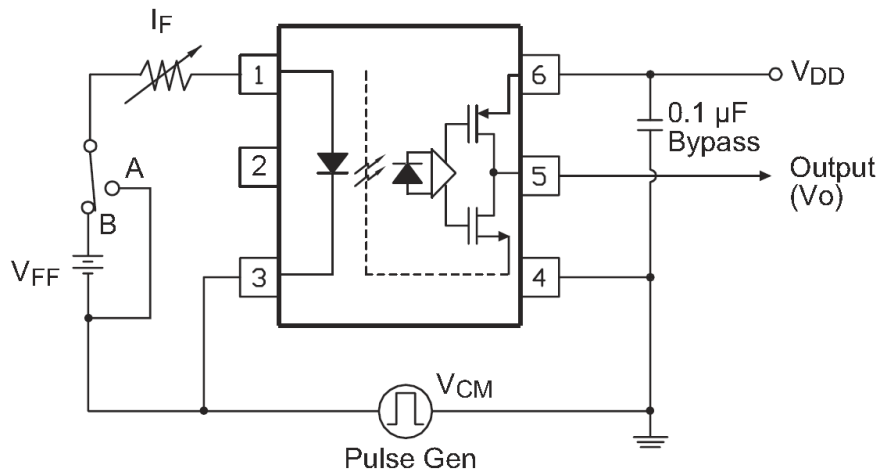

Figure 14. Test Circuit for Instantaneous Common Mode Rejection Voltage

REFLOW PROFILE

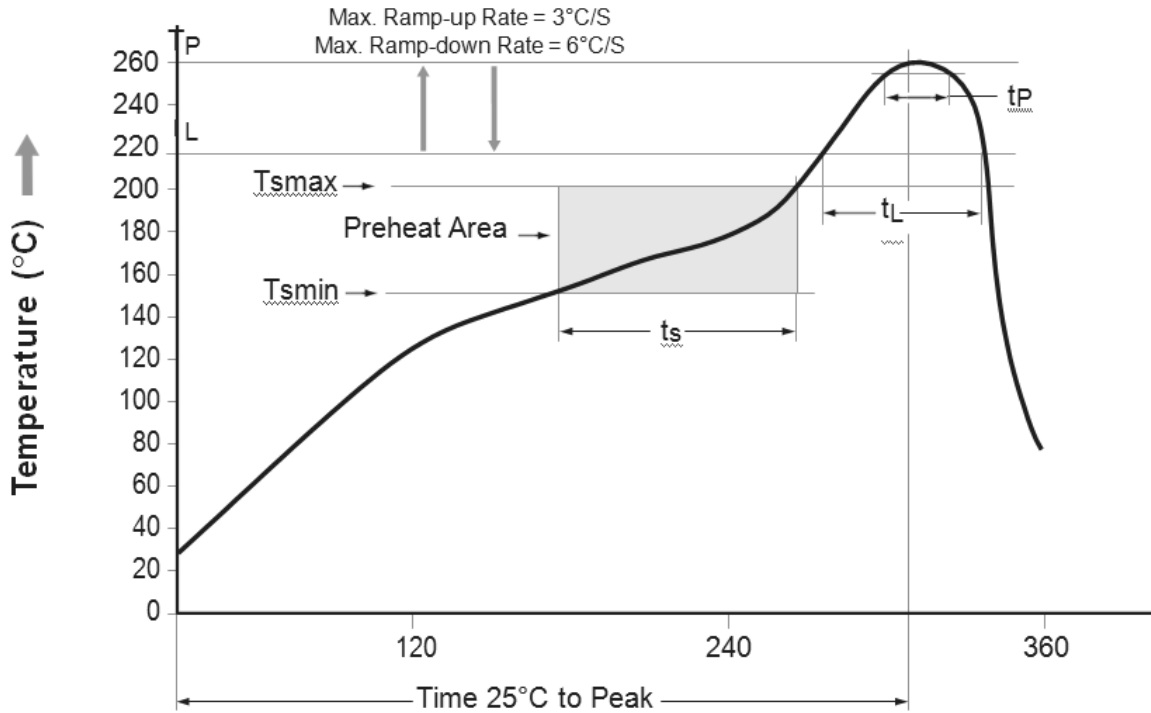

Figure 15. Reflow Profile

Table 8. REFLOW PROFILE

Profile Feature	Pb-Free Assembly Profile
Temperature Min. (Tsmín)	150 °C
Temperature Max. (Tsmáx)	200 °C
Time (ts) from (Tsmín to Tsmáx)	60 – 120 seconds
Ramp-up Rate (tL to tP)	3 °C/second max
Liquidous Temperature (TL)	217 °C
Time (tL) Maintained Above (TL)	60 – 150 seconds
Peak Body Package Temperature	260 °C + 0 °C / -5 °C
Time (tP) within 5 °C of 260 °C	30 seconds
Ramp-down Rate (TP to TL)	6 °C / second max.
Time 25 °C to Peak Temperature	8 minutes max.

FOD8173, FOD8173T

Table 9. ORDERING INFORMATION

Part Number	Package	Shipping†
FOD8173	Stretched Body SOP 6-Pin	100 Units / Tube
FOD8173V	Stretched Body SOP 6-Pin, DIN EN/IEC60747-5-5 Option (pending)	100 Units / Tube
FOD8173R2V	Stretched Body SOP 6-Pin, DIN EN/ IEC60747-5-5 Option (pending)	1000 / Tape and Reel
FOD8173T	Stretched Body SOP 6-Pin, Wide Lead	100 Units / Tube
FOD8173TR2	Stretched Body SOP 6-Pin, Wide Lead	1000 / Tape and Reel
FOD8173TV	Stretched Body SOP 6-Pin, Wide Lead, DIN EN/IEC60747-5-5 Option (pending)	100 Units / Tube
FOD8173TR2V	Stretched Body SOP 6-Pin, Wide Lead, DIN EN/ IEC60747-5-5 Option (pending)	1000 / Tape and Reel

DISCONTINUED (Note 7)

FOD8173R2	Stretched Body SOP 6-Pin	1000 / Tape and Reel
-----------	--------------------------	----------------------

† For information on tape and reel specifications, including part orientation and tape sizes, please refer to our Tape and Reel Packaging Specifications Brochure, [BRD8011/D](#).

7. **DISCONTINUED:** This device is not available. Please contact your **onsemi** representative for information. The most current information on this device may be available on www.onsemi.com.

FOD8173, FOD8173T

REVISION HISTORY

Revision	Description of Changes	Date
2	Rebranded the Data Sheet to onsemi format. FOD8173R2 OPN Marked as Discontinued.	07/01/2025

SOIC6
CASE 751EL
ISSUE O

DATE 30 SEP 2016

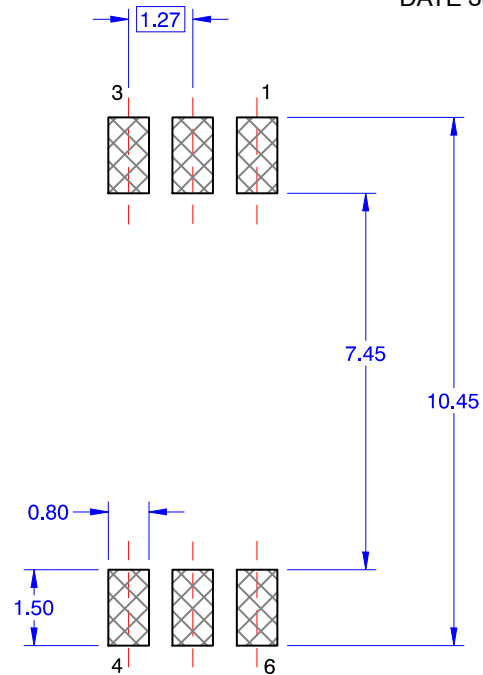
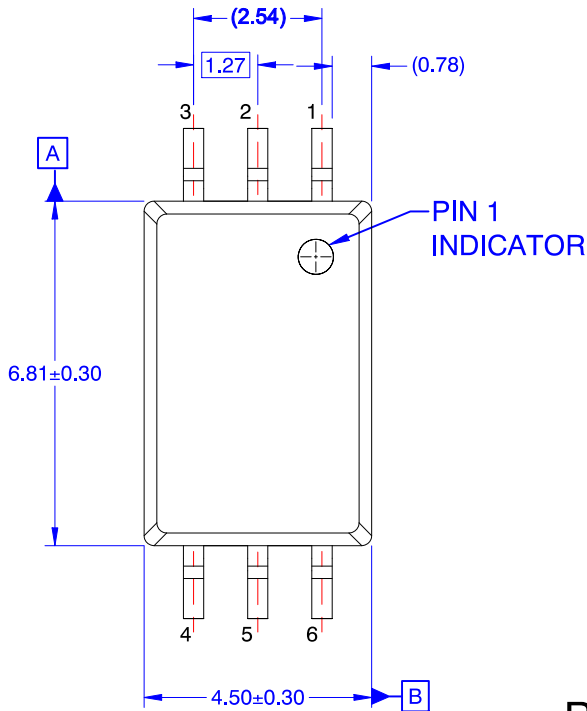

RECOMMENDED LAND PATTERN

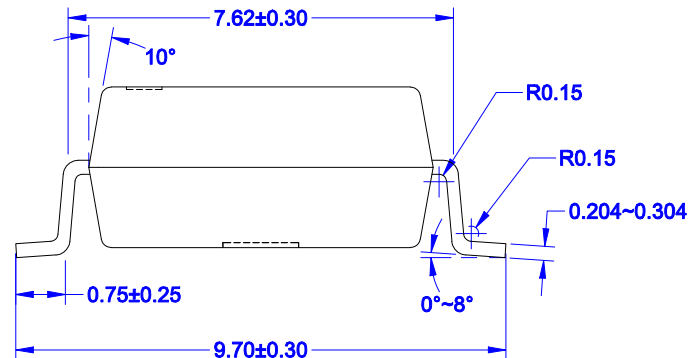
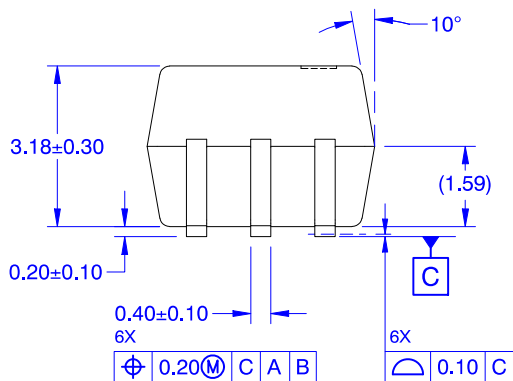

NOTES: UNLESS OTHERWISE SPECIFIED

- A) NO STANDARD APPLIES TO THIS PACKAGE
- B) ALL DIMENSIONS ARE IN MILLIMETERS.
- C) DIMENSIONS DO NOT INCLUDE BURRS OR MOLD FLASH, AND TIE BAR EXTRUSION.
- D) DIMENSIONING AND TOLERANCING PER ASME Y14.5M-2009.

DOCUMENT NUMBER:	98AON13745G	Electronic versions are uncontrolled except when accessed directly from the Document Repository. Printed versions are uncontrolled except when stamped "CONTROLLED COPY" in red.
DESCRIPTION:	SOIC6	PAGE 1 OF 1

onsemi and ONSEMI are trademarks of Semiconductor Components Industries, LLC dba onsemi or its subsidiaries in the United States and/or other countries. onsemi reserves the right to make changes without further notice to any products herein. onsemi makes no warranty, representation or guarantee regarding the suitability of its products for any particular purpose, nor does onsemi assume any liability arising out of the application or use of any product or circuit, and specifically disclaims any and all liability, including without limitation special, consequential or incidental damages. onsemi does not convey any license under its patent rights nor the rights of others.

onsemi, **Onsemi**, and other names, marks, and brands are registered and/or common law trademarks of Semiconductor Components Industries, LLC dba "**onsemi**" or its affiliates and/or subsidiaries in the United States and/or other countries. **onsemi** owns the rights to a number of patents, trademarks, copyrights, trade secrets, and other intellectual property. A listing of **onsemi**'s product/patent coverage may be accessed at www.onsemi.com/site/pdf/Patent-Marking.pdf. **onsemi** reserves the right to make changes at any time to any products or information herein, without notice. The information herein is provided "as-is" and **onsemi** makes no warranty, representation or guarantee regarding the accuracy of the information, product features, availability, functionality, or suitability of its products for any particular purpose, nor does **onsemi** assume any liability arising out of the application or use of any product or circuit, and specifically disclaims any and all liability, including without limitation special, consequential or incidental damages. Buyer is responsible for its products and applications using **onsemi** products, including compliance with all laws, regulations and safety requirements or standards, regardless of any support or applications information provided by **onsemi**. "Typical" parameters which may be provided in **onsemi** data sheets and/or specifications can and do vary in different applications and actual performance may vary over time. All operating parameters, including "Typicals" must be validated for each customer application by customer's technical experts. **onsemi** does not convey any license under any of its intellectual property rights nor the rights of others. **onsemi** products are not designed, intended, or authorized for use as a critical component in life support systems or any FDA Class 3 medical devices or medical devices with a same or similar classification in a foreign jurisdiction or any devices intended for implantation in the human body. Should Buyer purchase or use **onsemi** products for any such unintended or unauthorized application, Buyer shall indemnify and hold **onsemi** and its officers, employees, subsidiaries, affiliates, and distributors harmless against all claims, costs, damages, and expenses, and reasonable attorney fees arising out of, directly or indirectly, any claim of personal injury or death associated with such unintended or unauthorized use, even if such claim alleges that **onsemi** was negligent regarding the design or manufacture of the part. **onsemi** is an Equal Opportunity/Affirmative Action Employer. This literature is subject to all applicable copyright laws and is not for resale in any manner.

ADDITIONAL INFORMATION

TECHNICAL PUBLICATIONS:

Technical Library: www.onsemi.com/design/resources/technical-documentation
onsemi Website: www.onsemi.com

ONLINE SUPPORT: www.onsemi.com/support

For additional information, please contact your local Sales Representative at www.onsemi.com/support/sales