

28 V / 4 A Rated OVP with Low On-resistance

FPF2286UCX

FPF2286 is an OVP with integrated low on-resistance single channel switch. The device contains an N-MOSFET that can operate over an input voltage range of 2.8 V to 23 V and can support a maximum continuous current of 4 A.

When the input voltage exceeds the over-voltage threshold, the internal FET is turned off immediately to prevent damage to the protected downstream components.

FPF2286 is available in a small 6-bump WLCSP package and operate over the free-air temperature range of $-40\text{ }^{\circ}\text{C}$ to $+85\text{ }^{\circ}\text{C}$.

Features

- Over-voltage Protection Up to +28 V
- Internal Low $R_{DS(on)}$ NMOS Transistors: Typical 25 m Ω
- Programmable Over-voltage Lockout (OVLO)
 - ◆ Externally Adjustable via OVLO Pin
- Active-low Enable Pin (OVLO) for Device
- Super Fast OVLO Response Time: Typical 40 ns
- Short Circuit Protection and Auto-restart
- Over Temperature Protection (Thermal Shutdown)
- Robust ESD Performance
 - ◆ 2 kV Human Body Model (HBM)
 - ◆ 1 kV Charged Device Model (CDM)
 - ◆ V_{IN} Tolerant to 35 V Residue-voltage during Surge Event
- These Devices are Pb-Free, Halogen Free/BFR Free and are RoHS Compliant

Typical Applications

- Mobile Phones
- PDAs
- GPS



WLCSP6
CASE 567UV

MARKING DIAGRAM

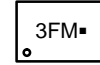

- 3F = Specific Device Code
 M = Month Code
 ■ = Pb-Free Package

PIN CONNECTIONS

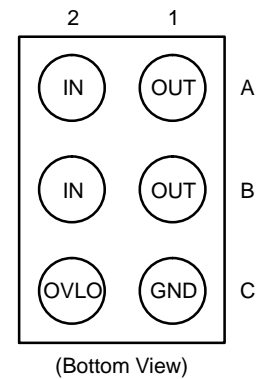

ORDERING INFORMATION

See detailed ordering, marking and shipping information on page 5 of this data sheet.

FPF2286UCX

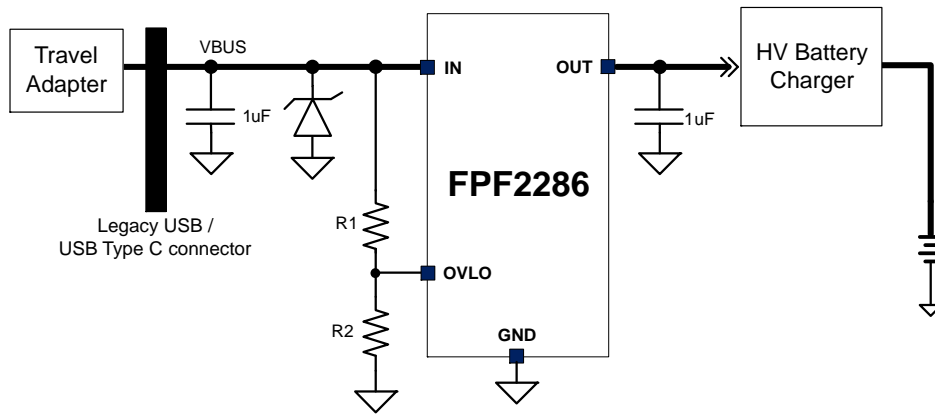

Figure 1. Application Schematic – Adjustable Option

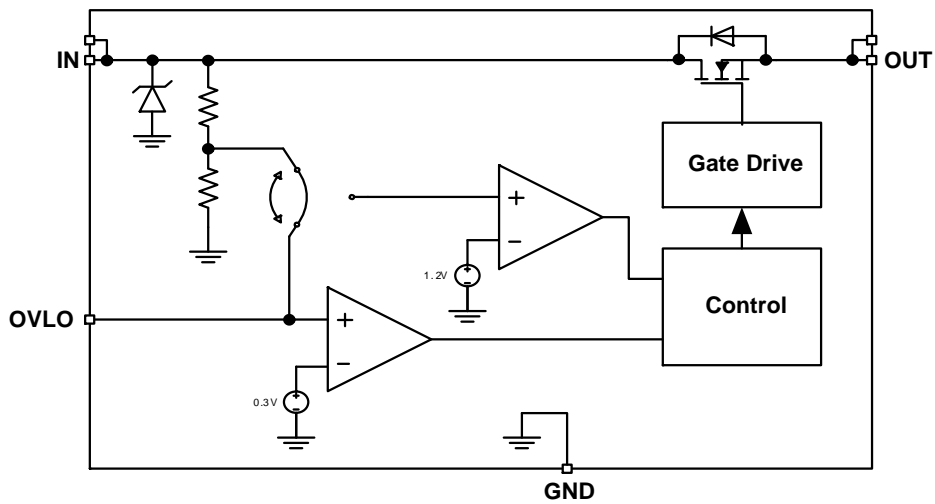

Figure 2. Simplified Block Diagram

Table 1. PIN FUNCTION DESCRIPTION

Pin No.	Pin Name	Description
A2, B2	IN	Power Input: Switch Input and Device Supply
A1, B1	OUT	Power Output: Switch Output to Load
C2	OVLO	OVLO Input: Over Voltage Lockout Adjustment Input
C1	GND	Ground

FPF2286UCX

Table 2. MAXIMUM RATINGS

Rating	Symbol	Value	Unit
Input Voltage Range (Note 1)	V_{in}	-0.3 to 28	V
Output Voltage Range	V_{out}	-0.3 to ($V_{in} + 0.3$)	V
Adjustable Input Range	V_{OVLO}	-0.3 to 23	V
Internal FET continuous current	I_{OUT}	0 to 4	A
Maximum Junction Temperature	$T_{J(max)}$	150	°C
Storage Temperature Range	T_{STG}	-65 to 150	°C
ESD Capability, Human Body Model (Note 2)	ESD_{HBM}	2	kV
ESD Capability, Charged Device Model (Note 2)	ESD_{CDM}	1	kV
Lead Temperature Soldering Reflow (SMD Styles Only), Pb-Free Versions (Note 3)	T_{SLD}	260	°C

Stresses exceeding those listed in the Maximum Ratings table may damage the device. If any of these limits are exceeded, device functionality should not be assumed, damage may occur and reliability may be affected.

1. Refer to ELECTRICAL CHARACTERISTICS, RECOMMENDED OPERATING RANGES and/or APPLICATION INFORMATION for Safe Operating parameters.
2. This device series incorporates ESD protection and is tested by the following methods:
ESD Human Body Model tested per AEC-Q100-002 (EIA/JESD22-A114)
ESD Charged Device Model tested per AEC-Q100-011 (EIA/JESD22-C101)
Latch-up Current Maximum Rating: ≤150 mA per JEDEC standard: JESD78
3. For information, please refer to our Soldering and Mounting Techniques Reference Manual, SOLDERRM/D.

Table 3. THERMAL CHARACTERISTICS

Rating	Symbol	Value	Unit
Thermal Characteristics, WLCSP-6 (Note 4) Thermal Resistance, Junction-to-Air (Note 5)	$R_{\theta JA}$	121.7	°C/W

4. Refer to ELECTRICAL CHARACTERISTICS, RECOMMENDED OPERATING RANGES and/or APPLICATION INFORMATION for Safe Operating parameters.
5. Values based on 2S2P JEDEC std. PCB.

Table 4. RECOMMENDED OPERATING RANGES

Rating	Symbol	Min	Max	Unit
Supply Voltage on VIN	V_{in}	2.8	23	V
I/O pins	V_{OVLO}	0	5.5	V
Output Current	I_{out}	0	3.5	A
IN Capacitor	C_{in}	0.1		μF
OUT Capacitor	C_{out}	0.1		μF
Ambient Temperature	T_A	-40	85	°C

Functional operation above the stresses listed in the Recommended Operating Ranges is not implied. Extended exposure to stresses beyond the Recommended Operating Ranges limits may affect device reliability.

FPF2286UCX

Table 5. ELECTRICAL CHARACTERISTICS

$V_{IN} = 2.8$ to 23 V, $C_{IN} = 0.1$ μ F, $C_{OUT} = 0.1$ μ F, $T_A = -40$ to 85 °C; For typical values $V_{IN} = 5.0$ V, $I_{IN} \leq 3$ A, $C_{IN} = 0.1$ μ F, $T_A = 25$ °C, for min/max values $T_A = -40$ °C to 85 °C; unless otherwise noted. (Note 6)

Parameter	Test Conditions	Symbol	Min	Typ	Max	Unit
-----------	-----------------	--------	-----	-----	-----	------

LEAKAGE AND QUIESCENT CURRENTS

Input Quiescent Current on VIN	$V_{IN} = 5$ V, $V_{OVLO} = 0.6$ V	I_Q		85		μ A
	$V_{IN} = 20$ V, $V_{OVLO} = 0.6$ V			200		
Supply Current during Over Voltage	$V_{IN} = 23$ V, $V_{OVLO} = 3.0$ V, $V_{OUT} = 0$ V	I_{IN_Q}		215		μ A
OVLO Input Leakage Current	$V_{OVLO} = V_{OVLO_TH}$	I_{OVLO}	-100		100	nA

OVER VOLTAGE AND UNDER VOLTAGE LOCKOUT

Under-Voltage Rising Trip Level for VIN	V_{IN} rising, $T_A = -40$ to 85 °C	$V_{IN_UV_R}$	2.3	2.5	2.7	V
Under-Voltage Falling Trip Level for VIN	V_{IN} falling, $T_A = -40$ to 85 °C	$V_{IN_UV_F}$		2.4		V
Default Over-Voltage Trip Level	V_{IN} rising, $T_A = -40$ to 85 °C	V_{IN_OVLO}	6.6	6.8	7.0	V
OVLO set threshold	$V_{OVLO} = 1.1$ V to 1.3 V, the voltage of OVLO to trigger Over Voltage condition	V_{OVLO_TH}	1.16	1.19	1.22	V
OVLO threshold hysteresis		V_{HYS_OVLO}		2		%
Adjustable OVLO range	$OV_MODE = 0$, $V_{OVLO} > 0.5$ V	V_{OV_RNG}	4		23	V

I/O THRESHOLDS

OVLO Input Threshold Voltage Voltage Increasing, Logic High Voltage Decreasing, Logic Low	High	V_{IH_OVLO}	0.3	-	-	V
	Low	V_{IL_OVLO}	-	-	0.15	

RESISTANCE

On-resistance of Power FET	$V_{IN} = 5$ V, $I_{OUT} = 500$ mA, $T_A = 25$ °C	r_{ON}		25	35	$m\Omega$
----------------------------	---	----------	--	----	----	-----------

TIMING

De-bounce Time of Power FET turned on	Time from 2.5 V $< V_{IN} < V_{IN_OVLO}$ to $V_{OUT} = 0.1 \times V_{IN}$	t_{SW_DEB}		15		ms
Switch Turn-On rising Time (Note 8)	$V_{IN} = 5$ V, $R_L = 100$ Ω , $C_L = 22$ μ F, V_{OUT} from $0.1 \times V_{IN}$ to $0.9 \times V_{IN}$	t_R		1		ms
Switch Turn-Off Time (Note 8)	$R_L = 10$ Ω , $C_L = 0$ μ F, time from $V_{IN} > V_{OVLO}$ to $V_{OUT} = 0.9 \times V_{IN}$ Internal OVP level External OVP level (Note 9)			40 100		ns

THERMAL SHUTDOWN

Thermal Shutdown Temperature (Note 8)		T_{SD}	-	130	-	°C
Thermal Shutdown Hysteresis (Note 8)		T_{SH}	-	20	-	°C

Product parametric performance is indicated in the Electrical Characteristics for the listed test conditions, unless otherwise noted. Product performance may not be indicated by the Electrical Characteristics if operated under different conditions.

- Performance guaranteed over the indicated operating temperature range by design and/or characterization tested at $T_J = T_A = 25$ °C. Low duty cycle pulse techniques are used during testing to maintain the junction temperature as close to ambient as possible.
- Refer to the APPLICATION INFORMATION section.
- Values based on design and/or characterization.
- Depends on the capacitance on OVLO pin.

FPF2286UCX

Function Description

General

FPF2286 is an OVP power switch to protect next stage system which is optimized to lower voltage working condition. The device includes ultra low on-resistance power FET (25 mΩ) and super fast OVP response time (40 ns).

Power MOSFET

The FPF2286 integrates an N-type MOSFET with 25 mΩ resistance. The power FET can work under 2.8 V ~ 23 V and up to 4 A DC current capability.

Power Supply

The FPF2286 is supplied by IN. IN will be firstly supplied by OUT when the device is working under USB On-The-Go (OTG) condition.

Enable Control

There is no specified enable pin for FPF2286. However, the OVLO can be used as an active LOW enable pin to be controlled by a GPIO. When OVLO pin is connected to a high level (higher than 1.2 V), the internal FET will be turned off. When OVLO pin is connected to 0 V, the FET will be turned on as long as V_{IN} is not higher than 6.8 V.

Under Voltage Lockout

FPF2286 power switch will be turned off when the voltage on IN is lower than the UVLO threshold V_{IN_UV_F}. Whenever V_{IN} voltage ramps up to higher than V_{IN_UV_R}, the power FET will be turned on automatically after t_{DEB} de-bounce time if there is no OV or OT condition.

Over Voltage Lockout

The power FET will be turned off whenever V_{IN} voltage higher than V_{IN_OVLO}. The value of V_{IN_OVLO} can be set by external resistor ladder or just be default value V_{IN_OVLO}.

When V_{OVLO} is smaller than V_{IL_OVLO}, V_{OVLO} will be decided by default value. When V_{OVLO} is larger than V_{IH_OVLO}, the power switch will be turned off once V_{OVLO} > V_{OVLO_TH}. The external resistor ladder can be decided according to the following equation:

$$V_{IN_OVLO} = V_{OVLO_TH} \times (1 + R1/R2) \quad (\text{eq. 1})$$

where R1 and R2 are the resistors in Figure 1.

Thermal Shutdown

When the device is in the switch mode, to protect the device from over temperature, the power switch will be turned off when the junction temperature exceeds T_{SD}. The switch will be turned on again when temperature drop below T_{SD} - T_{SH}.

APPLICATIONS INFORMATION

Input Decoupling (C_{in})

A ceramic or tantalum at least 0.1 μF capacitor is recommended and should be connected close to the FPF2286 package. Higher capacitance and lower ESR will improve the overall line and load transient response.

Output Decoupling (C_{out})

The FPF2286 is a stable component and does not require a minimum Equivalent Series Resistance (ESR) for the output capacitor. The minimum output decoupling value is 0.1 μF and can be augmented to fulfill stringent load transient requirements.

Thermal Considerations

As power in the FPF2286 increases, it might become necessary to provide some thermal relief. The maximum power dissipation supported by the device is dependent upon board design and layout. Mounting pad configuration on the PCB, the board material, and the ambient temperature affect the rate of junction temperature rise for the part. When

the FPF2286 has good thermal conductivity through the PCB, the junction temperature will be relatively low with high power applications. The maximum dissipation the FPF2286 can handle is given by:

$$P_{D(MAX)} = \frac{[T_{J(MAX)} - T_A]}{R_{\theta JA}} \quad (\text{eq. 2})$$

Since T_J is not recommended to exceed 125 °C, then the FPF2286 soldered on 645 mm², 1 oz copper area, and the ambient temperature (T_A) is 25 °C. The power dissipated by the FPF2286 can be calculated from the following equations:

$$P_D \approx V_{in} \cdot (I_Q @ I_{out}) + I_{out}^2 \cdot r_{ON} \quad (\text{eq. 3})$$

Hints

V_{in} and V_{out} printed circuit board traces should be as wide as possible. Place external components, especially the input capacitor and TVS, as close as possible to the FPF2286, and make traces as short as possible.

ORDERING INFORMATION

Device	Default OV Level	Marking	Package	Shipping†
FPF2286UCX	6.8 V	3F	WLCSP-6L	3000 / Tape & Reel

†For information on tape and reel specifications, including part orientation and tape sizes, please refer to our Tape and Reel Packaging Specifications Brochure, BRD8011/D.

WLCSP6 1.3x0.9x0.574
CASE 567UV
ISSUE O

DATE 05 JUL 2017

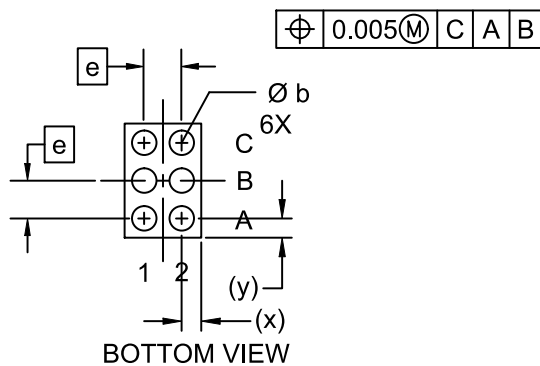
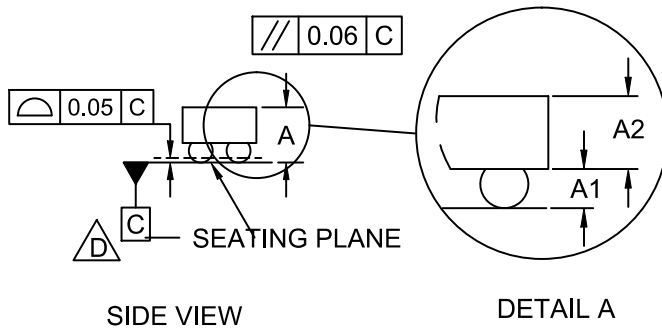
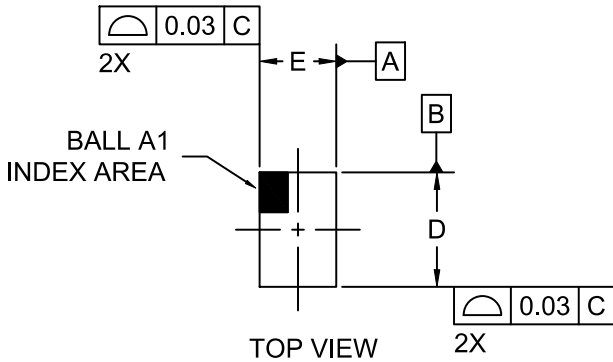

NOTES:

1. DIMENSIONING AND TOLERANCING PER ASME Y14.5M, 2009.
2. CONTROLLING DIMENSION: MILLIMETERS
3. DATUM C APPLIES TO THE SPHERICAL CROWN OF THE SOLDER BALLS

DIM	MILLIMETERS		
	MIN.	NOM.	MAX.
A	0.536	0.574	0.612
A1	0.176	0.196	0.216
A2	0.360	0.378	0.396
b	0.240	0.260	0.280
D	1.270	1.300	1.330
E	0.870	0.900	0.930
e	0.40 BSC		
x	0.235	0.250	0.265
y	0.235	0.250	0.265

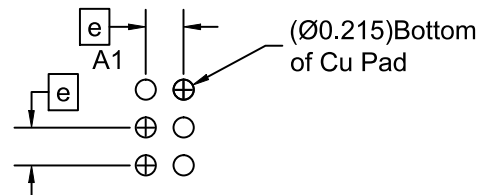

RECOMMENDED MOUNTING FOOTPRINT (NSMD PAD TYPE)

DOCUMENT NUMBER:	98AON66547G	Electronic versions are uncontrolled except when accessed directly from the Document Repository. Printed versions are uncontrolled except when stamped "CONTROLLED COPY" in red.
DESCRIPTION:	WLCSP6 1.3x0.9x0.574	PAGE 1 OF 1

onsemi and ONSEMI are trademarks of Semiconductor Components Industries, LLC dba onsemi or its subsidiaries in the United States and/or other countries. onsemi reserves the right to make changes without further notice to any products herein. onsemi makes no warranty, representation or guarantee regarding the suitability of its products for any particular purpose, nor does onsemi assume any liability arising out of the application or use of any product or circuit, and specifically disclaims any and all liability, including without limitation special, consequential or incidental damages. onsemi does not convey any license under its patent rights nor the rights of others.

onsemi, **Onsemi**, and other names, marks, and brands are registered and/or common law trademarks of Semiconductor Components Industries, LLC dba "**onsemi**" or its affiliates and/or subsidiaries in the United States and/or other countries. **onsemi** owns the rights to a number of patents, trademarks, copyrights, trade secrets, and other intellectual property. A listing of **onsemi**'s product/patent coverage may be accessed at www.onsemi.com/site/pdf/Patent-Marking.pdf. **onsemi** reserves the right to make changes at any time to any products or information herein, without notice. The information herein is provided "as-is" and **onsemi** makes no warranty, representation or guarantee regarding the accuracy of the information, product features, availability, functionality, or suitability of its products for any particular purpose, nor does **onsemi** assume any liability arising out of the application or use of any product or circuit, and specifically disclaims any and all liability, including without limitation special, consequential or incidental damages. Buyer is responsible for its products and applications using **onsemi** products, including compliance with all laws, regulations and safety requirements or standards, regardless of any support or applications information provided by **onsemi**. "Typical" parameters which may be provided in **onsemi** data sheets and/or specifications can and do vary in different applications and actual performance may vary over time. All operating parameters, including "Typicals" must be validated for each customer application by customer's technical experts. **onsemi** does not convey any license under any of its intellectual property rights nor the rights of others. **onsemi** products are not designed, intended, or authorized for use as a critical component in life support systems or any FDA Class 3 medical devices or medical devices with a same or similar classification in a foreign jurisdiction or any devices intended for implantation in the human body. Should Buyer purchase or use **onsemi** products for any such unintended or unauthorized application, Buyer shall indemnify and hold **onsemi** and its officers, employees, subsidiaries, affiliates, and distributors harmless against all claims, costs, damages, and expenses, and reasonable attorney fees arising out of, directly or indirectly, any claim of personal injury or death associated with such unintended or unauthorized use, even if such claim alleges that **onsemi** was negligent regarding the design or manufacture of the part. **onsemi** is an Equal Opportunity/Affirmative Action Employer. This literature is subject to all applicable copyright laws and is not for resale in any manner.

ADDITIONAL INFORMATION

TECHNICAL PUBLICATIONS:

Technical Library: www.onsemi.com/design/resources/technical-documentation
onsemi Website: www.onsemi.com

ONLINE SUPPORT: www.onsemi.com/support

For additional information, please contact your local Sales Representative at www.onsemi.com/support/sales