

PNP Epitaxial Silicon Transistor

FJL4215, 2SA1943

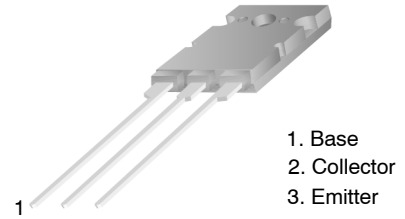

- 1. Base
- 2. Collector
- 3. Emitter

TO-264-3LD
CASE 340CA

Features

- High Current Capability: $I_C = 17\text{ A}$
- High Power Dissipation: 150 W
- High Frequency: 30 MHz
- High Voltage: $V_{CEO} = -250\text{ V}$
- Wide S.O.A. for Reliable Operation
- Excellent Gain Linearity for Low THD
- Complement to 2SC5200 / FJL4315
- Thermal and Electrical Spice Models are Available
- Same Transistor is also Available in:
 - ◆ TO3P Package, 2SA1962 / FJA4213 : 130 Watts
 - ◆ TO220 Package, FJP1943 : 80 Watts
 - ◆ TO220F Package, FJPF1943 : 50 Watts
- These Devices are Pb-Free and are RoHS Compliant

Applications

- High-Fidelity Audio Output Amplifier
- General Purpose Power Amplifier

MARKING DIAGRAM

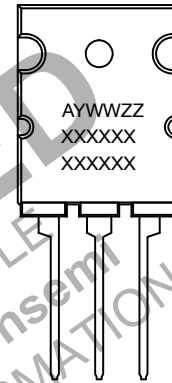

- A = Assembly Location
- YWW = Date Code
- ZZ = Assembly Lot
- xxxxx = Specific Device Code (J42150 or A19430)

ABSOLUTE MAXIMUM RATINGS ($T_A = 25\text{ }^\circ\text{C}$ unless otherwise noted)

Parameter	Symbol	Ratings	Unit
Collector-Base Voltage	BV_{CBO}	-250	V
Collector-Emitter Voltage	BV_{CEO}	-250	V
Emitter-Base Voltage	BV_{EBO}	-5	V
Collector Current (DC)	I_C	-17	A
Base Current	I_B	-1.5	A
Total Device Dissipation ($T_C = 25\text{ }^\circ\text{C}$)	P_D	150	W
Derate Above 25 $^\circ\text{C}$		1.04	W/ $^\circ\text{C}$
Junction and Storage Temperature	T_J, T_{STG}	-50 ~ +150	$^\circ\text{C}$

Stresses exceeding those listed in the Maximum Ratings table may damage the device. If any of these limits are exceeded, device functionality should not be assumed, damage may occur and reliability may be affected.

THERMAL CHARACTERISTICS (Note 1)

($T_A = 25\text{ }^\circ\text{C}$ unless otherwise noted)

Parameter	Symbol	Max.	Unit
Thermal Resistance, Junction to Case	$R_{\theta JC}$	0.83	$^\circ\text{C/W}$

1. Device mounted on minimum pad size.

h_{FE} CLASSIFICATION

Classification	R	O
h_{FE1}	55 ~ 110	80 ~ 160

ORDERING INFORMATION

See detailed ordering and shipping information on page 2 of this data sheet.

NOTE: Some of the devices on this data sheet have been **DISCONTINUED**. Please refer to the table on page 2.

FJL4215, 2SA1943

ELECTRICAL CHARACTERISTICS (Note 2) ($T_C = 25\text{ }^\circ\text{C}$ unless otherwise noted)

Symbol	Parameter	Conditions	Min	Typ	Max	Unit
BV_{CBO}	Collector-Base Breakdown Voltage	$I_C = 5\text{ mA}$, $I_E = 0$	-250			V
BV_{CEO}	Collector-Emitter Breakdown Voltage	$I_C = 10\text{ mA}$, $R_{BE} = \infty$	-250			V
BV_{EBO}	Emitter-Base Breakdown Voltage	$I_E = 5\text{ mA}$, $I_C = 0$	-5			V
I_{CBO}	Collector Cut-Off Current	$V_{CB} = -230\text{ V}$, $I_E = 0$			-5.0	μA
I_{EBO}	Emitter Cut-Off Current	$V_{EB} = -5\text{ V}$, $I_C = 0$			-5.0	μA
h_{FE1}	DC Current Gain	$V_{CE} = -5\text{ V}$, $I_C = -1\text{ A}$	55		160	
h_{FE2}	DC Current Gain	$V_{CE} = -5\text{ V}$, $I_C = -7\text{ A}$	35	60		
$V_{CE(sat)}$	Collector-Emitter Saturation Voltage	$I_C = -8\text{ A}$, $I_B = -0.8\text{ A}$		-0.4	-3.0	V
$V_{BE(on)}$	Base-Emitter On Voltage	$V_{CE} = -5\text{ V}$, $I_C = -7\text{ A}$		-1.0	-1.5	V
f_T	Current Gain Bandwidth Product	$V_{CE} = -5\text{ V}$, $I_C = -1\text{ A}$		30		MHz
C_{ob}	Output Capacitance	$V_{CB} = -10\text{ V}$, $f = 1\text{ MHz}$		360		pF

Product parametric performance is indicated in the Electrical Characteristics for the listed test conditions, unless otherwise noted. Product performance may not be indicated by the Electrical Characteristics if operated under different conditions.

2. Pulse Test: Pulse Width = 20 μs , Duty Cycle $\leq 2\%$

ORDERING INFORMATION

Part Number	Marking	Package	Shipping	Remarks
2SA1943OTU	A1943O	TO-264-3LD (Pb-Free)	375 Units / Tube	h_{FE1} O grade

DISCONTINUED (Note 3)

FJL4215OTU	J4215O	TO-264-3LD (Pb-Free)	375 Units / Tube	h_{FE1} O grade
------------	--------	----------------------	------------------	-------------------

3. **DISCONTINUED:** This device is not available. Please contact your **onsemi** representative for information. The most current information on this device may be available on www.onsemi.com.

TYPICAL CHARACTERISTICS

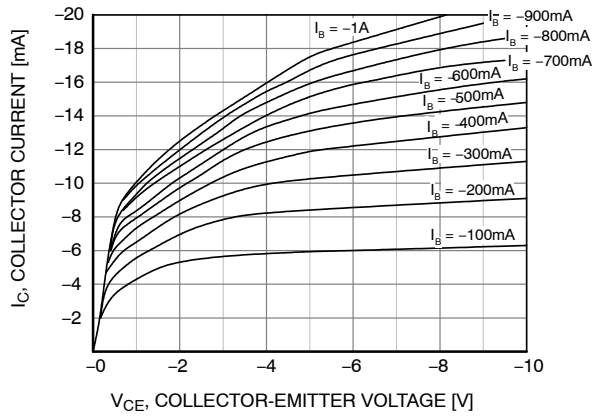

Figure 1. Static Characteristic

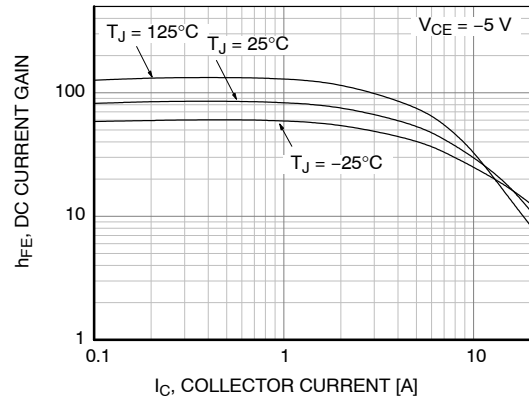

Figure 2. DC Current Gain (R Grade)

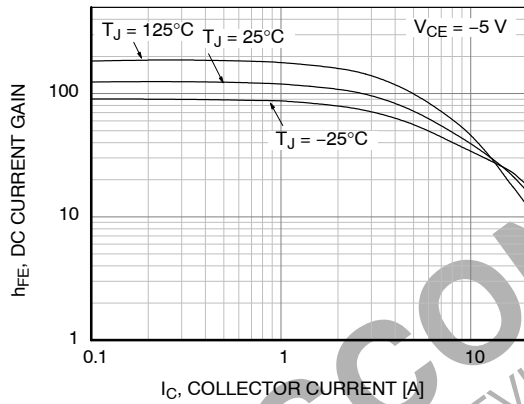

Figure 3. DC Current Gain (O Grade)

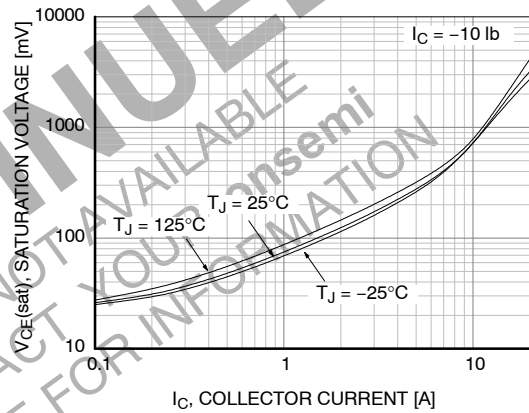

Figure 4. Collector-Emitter Saturation Voltage

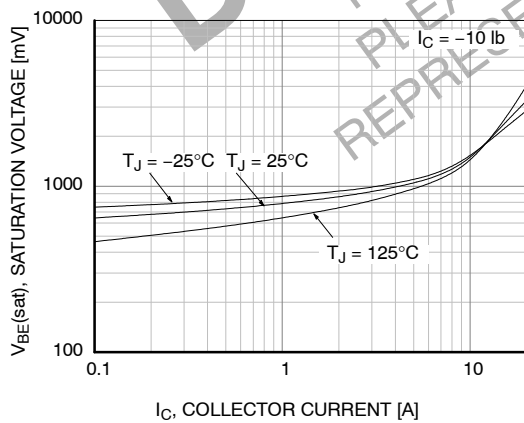

Figure 5. Base-Emitter Saturation Voltage

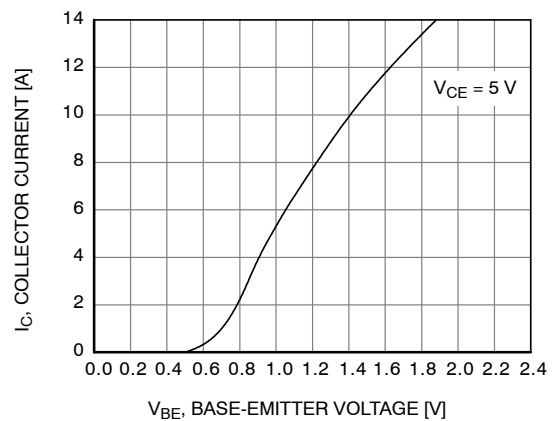

Figure 6. Base-Emitter On Voltage

TYPICAL CHARACTERISTICS

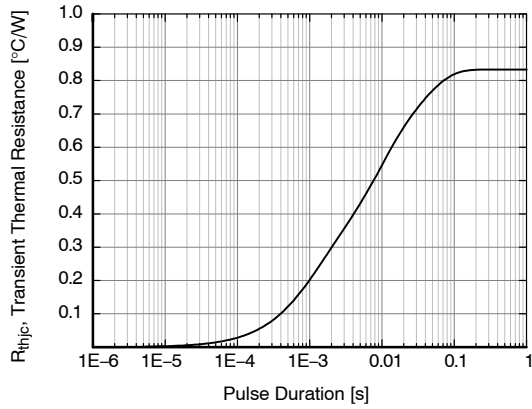

Figure 7. Thermal Resistance

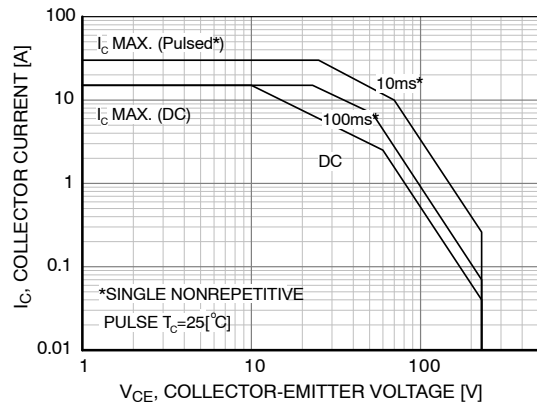

Figure 8. Safe Operating Area

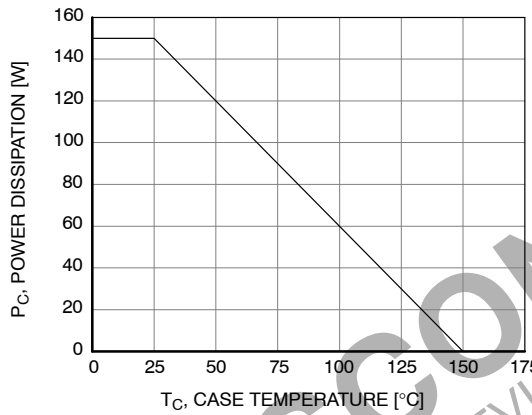

Figure 9. Power Derating

DISCONTINUED

THIS DEVICE IS NOT AVAILABLE
PLEASE CONTACT YOUR onsemi
REPRESENTATIVE FOR INFORMATION

FJL4215, 2SA1943

REVISION HISTORY

Revision	Description of Changes	Date
4	FJL4215OTU OPN Marked as Discontinued.	1/15/2026
5	Document Discontinued.	5/14/2026

This document has undergone updates prior to the inclusion of this revision history table. The changes tracked here only reflect updates made on the noted approval dates.

DISCONTINUED
THIS DEVICE IS NOT AVAILABLE
PLEASE CONTACT YOUR onsemi
REPRESENTATIVE FOR INFORMATION

TO-264-3LD
CASE 340CA
ISSUE O

DATE 31 OCT 2016

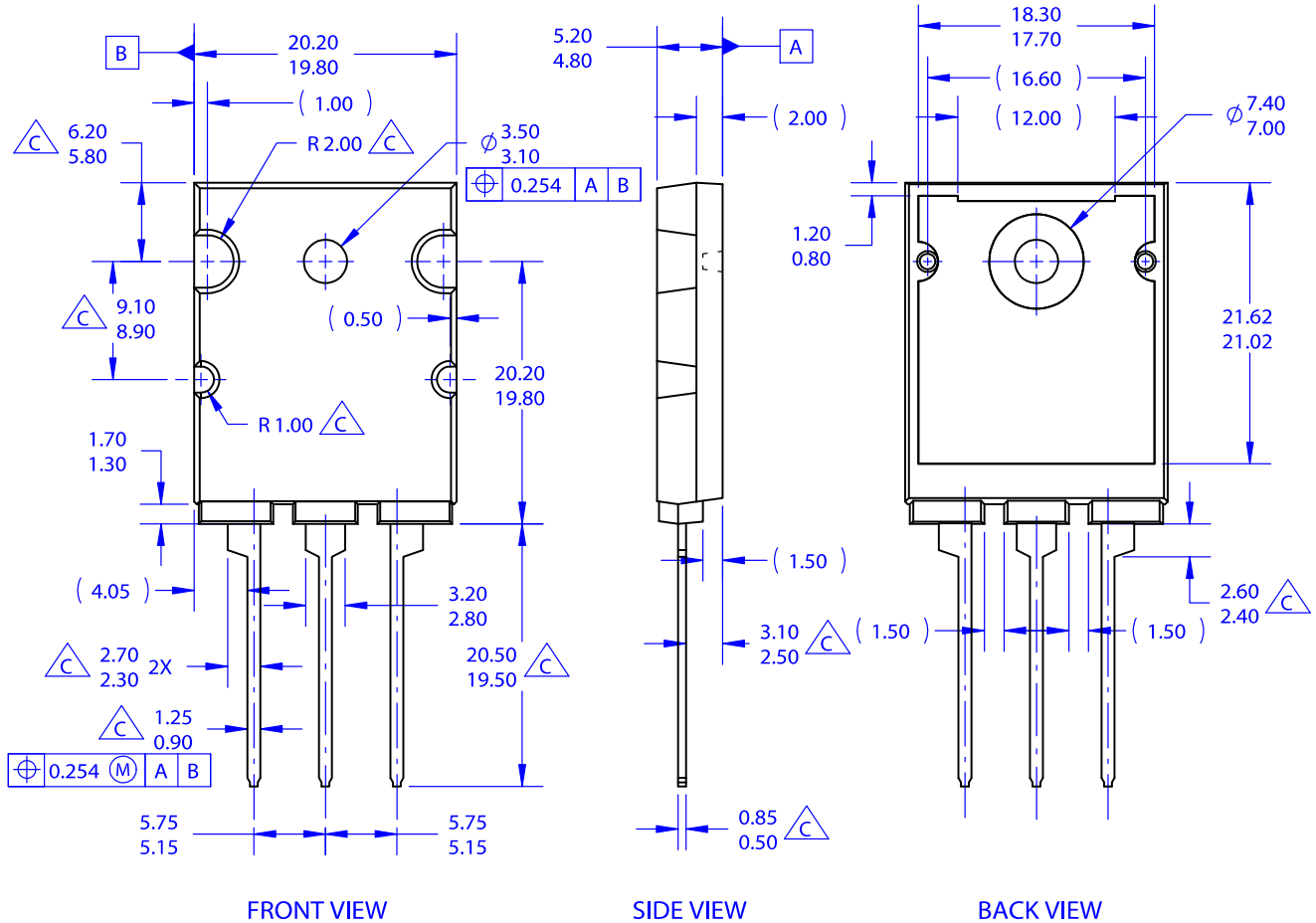

NOTES:

- A. PACKAGE REFERENCE: JEDEC TO264 VARIATION AA.
- B. ALL DIMENSIONS ARE IN MILLIMETERS.
- C. OUT OF JEDEC STANDARD VALUE.
- D. DIMENSION AND TOLERANCE AS PER ASME Y14.5-1994.
- E. DIMENSIONS ARE EXCLUSIVE OF BURRS, MOLD FLASH AND TIE BAR PROTRUSIONS.

DOCUMENT NUMBER:	98AON13860G	Electronic versions are uncontrolled except when accessed directly from the Document Repository. Printed versions are uncontrolled except when stamped "CONTROLLED COPY" in red.
DESCRIPTION:	TO-264-3LD	PAGE 1 OF 1

onsemi and Onsemi are trademarks of Semiconductor Components Industries, LLC dba onsemi or its subsidiaries in the United States and/or other countries. onsemi reserves the right to make changes without further notice to any products herein. onsemi makes no warranty, representation or guarantee regarding the suitability of its products for any particular purpose, nor does onsemi assume any liability arising out of the application or use of any product or circuit, and specifically disclaims any and all liability, including without limitation special, consequential or incidental damages. onsemi does not convey any license under its patent rights nor the rights of others.

onsemi, **Onsemi**, and other names, marks, and brands are registered and/or common law trademarks of Semiconductor Components Industries, LLC dba "**onsemi**" or its affiliates and/or subsidiaries in the United States and/or other countries. **onsemi** owns the rights to a number of patents, trademarks, copyrights, trade secrets, and other intellectual property. A listing of **onsemi**'s product/patent coverage may be accessed at www.onsemi.com/site/pdf/Patent-Marking.pdf. **onsemi** reserves the right to make changes at any time to any products or information herein, without notice. The information herein is provided "as-is" and **onsemi** makes no warranty, representation or guarantee regarding the accuracy of the information, product features, availability, functionality, or suitability of its products for any particular purpose, nor does **onsemi** assume any liability arising out of the application or use of any product or circuit, and specifically disclaims any and all liability, including without limitation special, consequential or incidental damages. Buyer is responsible for its products and applications using **onsemi** products, including compliance with all laws, regulations and safety requirements or standards, regardless of any support or applications information provided by **onsemi**. "Typical" parameters which may be provided in **onsemi** data sheets and/or specifications can and do vary in different applications and actual performance may vary over time. All operating parameters, including "Typicals" must be validated for each customer application by customer's technical experts. **onsemi** does not convey any license under any of its intellectual property rights nor the rights of others. **onsemi** products are not designed, intended, or authorized for use as a critical component in life support systems or any FDA Class 3 medical devices or medical devices with a same or similar classification in a foreign jurisdiction or any devices intended for implantation in the human body. Should Buyer purchase or use **onsemi** products for any such unintended or unauthorized application, Buyer shall indemnify and hold **onsemi** and its officers, employees, subsidiaries, affiliates, and distributors harmless against all claims, costs, damages, and expenses, and reasonable attorney fees arising out of, directly or indirectly, any claim of personal injury or death associated with such unintended or unauthorized use, even if such claim alleges that **onsemi** was negligent regarding the design or manufacture of the part. **onsemi** is an Equal Opportunity/Affirmative Action Employer. This literature is subject to all applicable copyright laws and is not for resale in any manner.

ADDITIONAL INFORMATION

TECHNICAL PUBLICATIONS:

Technical Library: www.onsemi.com/design/resources/technical-documentation
onsemi Website: www.onsemi.com

ONLINE SUPPORT: www.onsemi.com/support

For additional information, please contact your local Sales Representative at www.onsemi.com/support/sales