

## Linear Hall-Effect Sensor ICs with Analog Output Available in a Miniature, Low-Profile Surface-Mount Package

### FEATURES AND BENEFITS

- 5 V supply operation
- QVO temperature coefficient programmed at Allegro™ for improved accuracy
- AEC Q-100 qualified
- Miniature package options
- High-bandwidth, low-noise analog output
- High-speed chopping scheme minimizes QVO drift across operating temperature range
- Temperature-stable quiescent voltage output and sensitivity
- Precise recoverability after temperature cycling
- Output voltage clamps provide short-circuit diagnostic capabilities
- Undervoltage lockout (UVLO)
- Wide ambient temperature range:  $-40^{\circ}\text{C}$  to  $150^{\circ}\text{C}$  (SOT-23W and SIP -L temp range),  $-40^{\circ}\text{C}$  to  $125^{\circ}\text{C}$  (SIP -K temp range)
- Immune to mechanical stress
- Enhanced EMC performance for stringent automotive applications

### PACKAGES:

3-pin SOT-23W  
2 mm × 3 mm × 1 mm  
(suffix LH)



3-pin ultramini SIP  
1.5 mm × 4 mm × 3 mm  
(suffix UA)



Not to scale

### DESCRIPTION

New applications for linear output Hall-effect sensors, such as displacement and angular position, require higher accuracy and smaller package sizes. The Allegro A1308 and A1309 linear Hall-effect sensor ICs have been designed specifically to meet both requirements. These temperature-stable devices are available in both surface-mount and through-hole packages.

The accuracy of each device is enhanced via end-of-line optimization. Each device features nonvolatile memory to optimize device sensitivity and the quiescent voltage output (QVO: output in the absence of a magnetic field) for a given application or circuit. This A1308 and A1309 optimized performance is sustained across the full operating temperature range by programming the temperature coefficient for both sensitivity and QVO at Allegro end-of-line test.

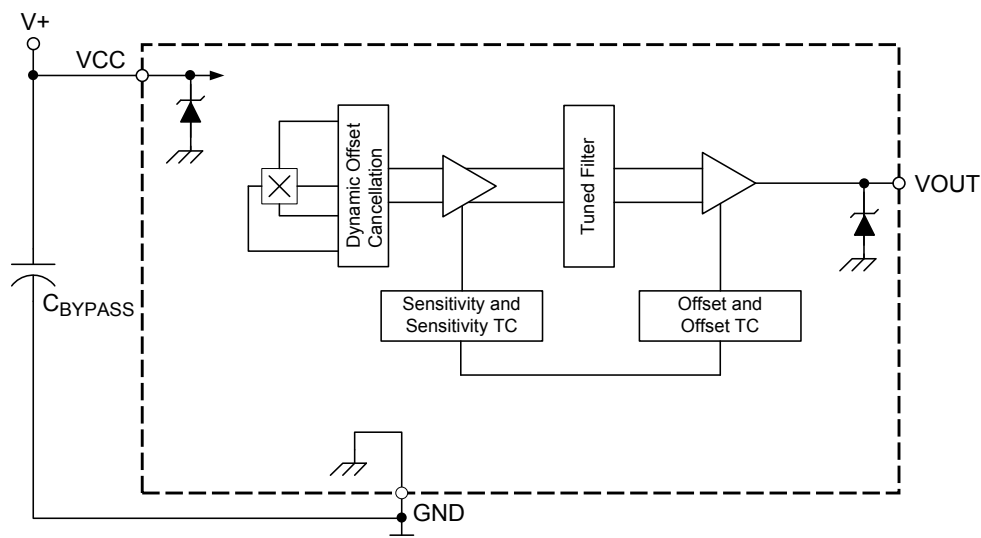
These ratiometric Hall-effect sensor ICs provide a voltage output that is proportional to the applied magnetic field. The quiescent voltage output is adjusted around 50% of the supply voltage.

The features of these linear devices make them ideal for use in automotive and industrial applications requiring high accuracy, and they operate across an extended temperature range,  $-40^{\circ}\text{C}$  to  $150^{\circ}\text{C}$  (SOT-23W and SIP -L temperature range) or  $-40^{\circ}\text{C}$  to  $125^{\circ}\text{C}$  (SIP -K temperature range).

Each BiCMOS monolithic circuit integrates a Hall element, temperature-compensating circuitry to reduce the intrinsic sensitivity drift of the Hall element, a small-signal high-gain

*Continued on the next page...*

### Functional Block Diagram



# A1308 and A1309

## Linear Hall-Effect Sensor ICs with Analog Output Available in a Miniature, Low-Profile Surface-Mount Package

### DESCRIPTION (Continued)

amplifier, a clamped low-impedance output stage, and a proprietary dynamic offset cancellation technique.

The A1308 and A1309 sensor ICs are offered in two package styles. The LH is a SOT-23W style, miniature, low-profile package for surface-mount applications. The UA is a 3-pin, ultramini, single inline package (SIP) for through-hole mounting. Both packages are lead (Pb) free, with 100% matte-tin leadframe plating.



### SELECTION GUIDE

Part Number	Output Polarity	Sensitivity (typ) (mV/G)	Operating Ambient Temperature Range (T <sub>A</sub> ) (°C)	Packing [1]	Package
A1308KUA-2-T	Forward	2.5	-40 to 125	500 pieces per bag	3-pin SIP through hole
A1308KUATN-1-T	Forward	1.3	-40 to 125	4,000 pieces per reel	3-pin SIP through hole
A1308KUATN-2-T	Forward	2.5	-40 to 125	4,000 pieces per reel	3-pin SIP through hole
A1308KUATN-3-T	Forward	3.125	-40 to 125	4,000 pieces per reel	3-pin SIP through hole
A1308KUATN-5-T	Forward	5	-40 to 125	4,000 pieces per reel	3-pin SIP through hole
A1308LUA-2-T	Forward	2.5	-40 to 150	500 pieces per bag	3-pin SIP through hole
A1308LLHLX-05-T	Forward	0.5	-40 to 150	10,000 pieces per reel	3-pin SOT-23W surface mount
A1308LLHLX-1-T	Forward	1.3	-40 to 150	10,000 pieces per reel	3-pin SOT-23W surface mount
A1308LLHLX-2-T	Forward	2.5	-40 to 150	10,000 pieces per reel	3-pin SOT-23W surface mount
A1308LLHLX-3-T	Forward	3.125	-40 to 150	10,000 pieces per reel	3-pin SOT-23W surface mount
A1308LLHLX-5-T	Forward	5	-40 to 150	10,000 pieces per reel	3-pin SOT-23W surface mount
A1309KUATN-9-T	Forward	9	-40 to 125	4,000 pieces per reel	3-pin SIP through hole
A1309LLHLX-9-T	Forward	9	-40 to 150	10,000 pieces per reel	3-pin SOT-23W surface mount
A1309LLHLX-RP9-T	Reverse	-9	-40 to 150	10,000 pieces per reel	3-pin SOT-23W surface mount

[1] Contact Allegro for additional packing options.

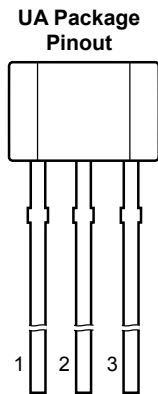
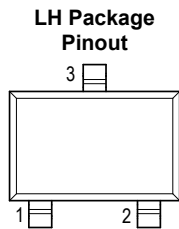
### ABSOLUTE MAXIMUM RATINGS

Characteristic	Symbol	Notes	Rating	Unit
Forward Supply Voltage	V <sub>CC</sub>		8	V
Reverse Supply Voltage	V <sub>RCC</sub>		-0.1	V
Forward Output Voltage	V <sub>OUT</sub>		7	V
Reverse Output Voltage	V <sub>ROUT</sub>		-0.1	V
Output Source Current	I <sub>OUT(SOURCE)</sub>	VOUT to GND	2	mA
Output Sink Current	I <sub>OUT(SINK)</sub>	VCC to VOUT	10	mA
Operating Ambient Temperature	T <sub>A</sub>	Range K	-40 to 125	°C
		Range L	-40 to 150	°C
Maximum Junction Temperature	T <sub>J(max)</sub>		165	°C
Storage Temperature	T <sub>stg</sub>		-65 to 170	°C

# A1308 and A1309

## Linear Hall-Effect Sensor ICs with Analog Output Available in a Miniature, Low-Profile Surface-Mount Package

### PINOUT DIAGRAMS AND TERMINAL LIST TABLE



**Terminal List Table**

Name	Number		Description
	LH	UA	
VCC	1	1	Input power supply; tie to GND with bypass capacitor
VOUT	2	3	Output signal
GND	3	2	Ground

**THERMAL CHARACTERISTICS: May require derating at maximum conditions; see application information**

Characteristic	Symbol	Test Conditions	Value	Units
Package Thermal Resistance	$R_{\theta JA}$	Package LH, 1-layer PCB with copper limited to solder pads	228	$^{\circ}\text{C}/\text{W}$
		Package LH, 2-layer PCB with 0.463 in <sup>2</sup> of copper area each side connected by thermal vias	110	$^{\circ}\text{C}/\text{W}$
		Package UA, 1-layer PCB with copper limited to solder pads	165	$^{\circ}\text{C}/\text{W}$

# A1308 and A1309

## Linear Hall-Effect Sensor ICs with Analog Output Available in a Miniature, Low-Profile Surface-Mount Package

**OPERATING CHARACTERISTICS:** Valid through  $T_A$ ,  $C_{BYPASS} = 0.1 \mu\text{F}$ ,  $V_{CC} = 5 \text{ V}$ , unless otherwise noted

Characteristics	Symbol	Test Conditions	Min.	Typ.	Max.	Unit [1]	
<b>ELECTRICAL CHARACTERISTICS</b>							
Supply Voltage	$V_{CC}$		4.5	5.0	5.5	V	
Undervoltage Threshold [2]	$V_{UVLOHI}$	K temp. option tested at $T_A = 25^\circ\text{C}$ to $125^\circ\text{C}$ (device powers on); L temp. option tested at $T_A = 25^\circ\text{C}$ to $150^\circ\text{C}$ (device powers on)	–	–	3	V	
	$V_{UVLOLO}$	K temp. option tested at $T_A = 25^\circ\text{C}$ to $125^\circ\text{C}$ (device powers off); L temp. option tested at $T_A = 25^\circ\text{C}$ to $150^\circ\text{C}$ (device powers off)	2.5	–	–	V	
Supply Current	$I_{CC}$	No load on VOUT	–	9	11.5	mA	
Power-On Time [3][4]	$t_{PO}$	$T_A = 25^\circ\text{C}$ , $C_{L(PROBE)} = 10 \text{ pF}$	–	50	–	$\mu\text{s}$	
$V_{CC}$ Ramp Time [3][4]	$t_{VCC}$	$T_A = 25^\circ\text{C}$	0.005	–	100	ms	
$V_{CC}$ Off Level [3][4]	$V_{CCOFF}$	$T_A = 25^\circ\text{C}$	0	–	0.55	V	
Delay to Clamp [3][4]	$t_{CLP}$	$T_A = 25^\circ\text{C}$ , $C_L = 10 \text{ nF}$	–	30	–	$\mu\text{s}$	
Supply Zener Clamp Voltage	$V_Z$	$T_A = 25^\circ\text{C}$ , $I_{CC} = 14.5 \text{ mA}$	6	7.3	–	V	
Internal Bandwidth [3]	$BW_i$	Small signal –3 dB	–	20	–	kHz	
Chopping Frequency [3][5]	$f_C$	$T_A = 25^\circ\text{C}$	–	400	–	kHz	
<b>OUTPUT CHARACTERISTICS</b>							
Output Referred Noise [3][6]	$V_N$	$V_{CC} = 5 \text{ V}$ , $T_A = 25^\circ\text{C}$ , $C_{BYPASS} = \text{open}$ , Sens $\geq 1.3 \text{ mV/G}$ , no load on VOUT	–	1.7	–	G	
		$V_{CC} = 5 \text{ V}$ , $T_A = 25^\circ\text{C}$ , $C_{BYPASS} = \text{open}$ , Sens = $0.5 \text{ mV/G}$ , no load on VOUT	–	2.8	–	G	
Input Referred RMS Noise Density [3]	$V_{NRMS}$	$V_{CC} = 5 \text{ V}$ , $T_A = 25^\circ\text{C}$ , $C_{BYPASS} = \text{open}$ , Sens $\geq 1.3 \text{ mV/G}$ , no load on VOUT	–	1.5	–	$\text{mG}/\sqrt{\text{Hz}}$	
		$V_{CC} = 5 \text{ V}$ , $T_A = 25^\circ\text{C}$ , $C_{BYPASS} = \text{open}$ , Sens = $0.5 \text{ mV/G}$ , no load on VOUT	–	2.5	–	$\text{mG}/\sqrt{\text{Hz}}$	
DC Output Resistance [3]	$R_{OUT}$		–	3	–	$\Omega$	
Output Load Resistance [3]	$R_L$	VOUT to GND	4.7	–	–	$\text{k}\Omega$	
Output Load Capacitance [3]	$C_L$	VOUT to GND	–	–	10	nF	
Output Voltage Clamp [7][8]	$V_{CLPHIGH}$	$T_A = 25^\circ\text{C}$ , $R_L = 10 \text{ k}\Omega$ (VOUT to GND)	4.35	4.5	4.65	V	
	$V_{CLFLOW}$	$T_A = 25^\circ\text{C}$ , $R_L = 10 \text{ k}\Omega$ (VOUT to VCC)	0.40	0.55	0.70	V	
Sensitivity	Sens	A1308KUA-2-T	$T_A = 25^\circ\text{C}$	2.4	2.5	2.6	$\text{mV/G}$
		A1308KUATN-1-T		1.17	1.3	1.43	$\text{mV/G}$
		A1308KUATN-2-T		2.4	2.5	2.6	$\text{mV/G}$
		A1308KUATN-3-T		3.025	3.125	3.225	$\text{mV/G}$
		A1308KUATN-5-T		4.85	5	5.15	$\text{mV/G}$
		A1308LUA-2-T		2.4	2.5	2.6	$\text{mV/G}$
		A1308LLHLX-05-T		0.43	0.5	0.57	$\text{mV/G}$
		A1308LLHLX-1-T		1.17	1.3	1.43	$\text{mV/G}$
		A1308LLHLX-2-T		2.4	2.5	2.6	$\text{mV/G}$
		A1308LLHLX-3-T		3.025	3.125	3.225	$\text{mV/G}$
		A1308LLHLX-5-T		4.85	5	5.15	$\text{mV/G}$
		A1309KUATN-9-T		8.73	9	9.27	$\text{mV/G}$
		A1309LLHLX-9-T		8.73	9	9.27	$\text{mV/G}$
		A1309LLHLX-RP9-T		–9.27	–9	–8.73	$\text{mV/G}$

Continued on the next page...

# A1308 and A1309

## Linear Hall-Effect Sensor ICs with Analog Output Available in a Miniature, Low-Profile Surface-Mount Package

**OPERATING CHARACTERISTICS (continued):** Valid through  $T_A$ ,  $C_{BYPASS} = 0.1 \mu\text{F}$ ,  $V_{CC} = 5 \text{ V}$ , unless otherwise noted

Characteristics	Symbol	Test Conditions	Min.	Typ.	Max.	Unit [1]	
<b>OUTPUT CHARACTERISTICS (continued)</b>							
Quiescent Voltage Output (QVO)	$V_{OUT(Q)}$	$T_A = 25^\circ\text{C}$	2.488	2.5	2.512	V	
Sensitivity Temperature Coefficient	$TC_{Sens}$	Programmed at $T_A = 125^\circ\text{C}$ (K temp. option) or $150^\circ\text{C}$ (L temp. option), calculated relative to Sens at $25^\circ\text{C}$	0.08	0.12	0.16	%/ $^\circ\text{C}$	
<b>ERROR COMPONENTS</b>							
Linearity Sensitivity Error	$Lin_{ERR}$		–	$\pm 1.5$	–	%	
Symmetry Sensitivity Error	$Sym_{ERR}$		–	$\pm 1.5$	–	%	
Ratiometry Quiescent Voltage Output Error <sup>[9]</sup>	$Rat_{V_{OUT(Q)}}$	Across supply voltage range (relative to $V_{CC} = 5 \text{ V}$ )	–	$\pm 1.5$	–	%	
Ratiometry Sensitivity Error <sup>[9]</sup>	$Rat_{Sens}$	Across supply voltage range (relative to $V_{CC} = 5 \text{ V}$ )	–	$\pm 1.5$	–	%	
Ratiometry Clamp Error <sup>[10]</sup>	$Rat_{V_{OUTCLP}}$	$T_A = 25^\circ\text{C}$ , across supply voltage range (relative to $V_{CC} = 5 \text{ V}$ )	–	$\pm 1.5$	–	%	
<b>DRIFT CHARACTERISTICS</b>							
Typical Quiescent Voltage Output Drift Across Temperature Range	$\Delta V_{OUT(Q)}$	A1308KUA-2-T	$T_A = 125^\circ\text{C}$	–10	0	10	mV
		A1308KUATN-1-T	$T_A = 125^\circ\text{C}$	–15	0	15	mV
		A1308KUATN-2-T	$T_A = 125^\circ\text{C}$	–10	0	10	mV
		A1308KUATN-3-T	$T_A = 125^\circ\text{C}$	–10	0	10	mV
		A1308KUATN-5-T	$T_A = 125^\circ\text{C}$	–20	0	10	mV
		A1308LUA-2-T	$T_A = 150^\circ\text{C}$	–10	–	–10	mV
		A1308LLHLX-05-T	$T_A = 150^\circ\text{C}$	–15	0	15	mV
		A1308LLHLX-1-T	$T_A = 150^\circ\text{C}$	–15	0	15	mV
		A1308LLHLX-2-T	$T_A = 150^\circ\text{C}$	–20	–	0	mV
		A1308LLHLX-3-T	$T_A = 150^\circ\text{C}$	–20	–	0	mV
		A1308LLHLX-5-T	$T_A = 150^\circ\text{C}$	–30	–	0	mV
		A1309KUATN-9-T	$T_A = 125^\circ\text{C}$	–20	0	10	mV
		A1309LLHLX-9-T	$T_A = 150^\circ\text{C}$	–30	–	0	mV
		A1309LLHLX-RP9-T	$T_A = 150^\circ\text{C}$	–30	–	0	mV
Sensitivity Drift Due to Package Hysteresis <sup>[11]</sup>	$\Delta Sens_{PKG}$	$T_A = 25^\circ\text{C}$ , after temperature cycling	–	$\pm 2$	–	%	

[1] 1 G (gauss) = 0.1 mT (millitesla),

[2] On power-up, the output of the device is held low until  $V_{CC}$  exceeds  $V_{UVLOHI}$ . After the device is powered, the output remains valid until  $V_{CC}$  drops below  $V_{UVLOLO}$ , when the output is pulled low.

[3] Determined by design and characterization, not evaluated at final test.

[4] See the Characteristic Definitions section.

[5]  $f_C$  varies as much as approximately  $\pm 20\%$  across the full operating ambient temperature range and process.

[6] Output Referred Noise is calculated as 6 sigma (6 standard deviations) from characterization of a small sample of devices. Conversion of noise from gauss to  $\text{mV}_{(P-P)}$  can be done by:  $\text{Noise (G)} \times \text{Sensitivity (mV/G)} = \text{Noise (mV}_{(P-P)})$ .

[7]  $V_{CLPLOW}$  and  $V_{CLPHIGH}$  scale with  $V_{CC}$  due to ratiometry.

[8] Parameter is tested at wafer probe only.

[9] Percent change from actual value at  $V_{CC} = 5 \text{ V}$ , for a given temperature.

[10] Percent change from actual value at  $V_{CC} = 5 \text{ V}$ ,  $T_A = 25^\circ\text{C}$ .

[11] Sensitivity drift through the life of the part,  $\Delta Sens_{LIFE}$ , can have a typical error value  $\pm 3\%$  in addition to package hysteresis effects.

### CHARACTERISTIC DEFINITIONS

**Power-On Time.** When the supply is ramped to its operating voltage, the device output requires a finite time to react to an input magnetic field. Power-On Time,  $t_{PO}$ , is defined as the time it takes for the output voltage to begin responding to an applied magnetic field after the power supply has reached its minimum specified operating voltage,  $V_{CC}(\text{min})$ , as shown in Figure 1.

**Delay to Clamp.** A large magnetic input step may cause the clamp to overshoot its steady-state value. The Delay to Clamp,  $t_{CLP}$ , is defined as the time it takes for the output voltage to settle within 1% of its steady-state value, after initially passing through its steady-state voltage, as shown in Figure 2.

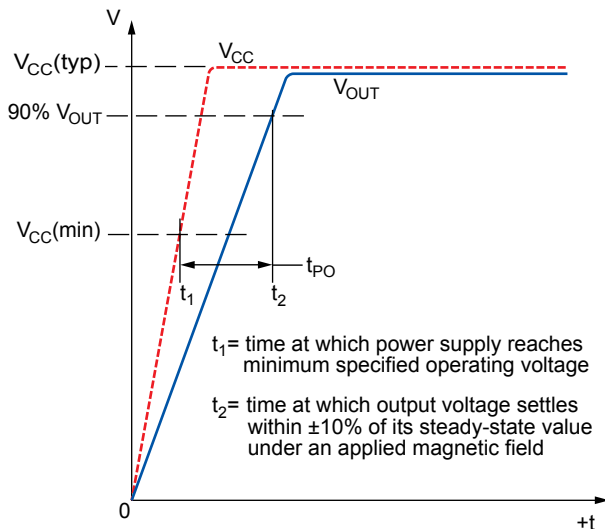


Figure 1: Definition of Power-On Time,  $t_{PO}$

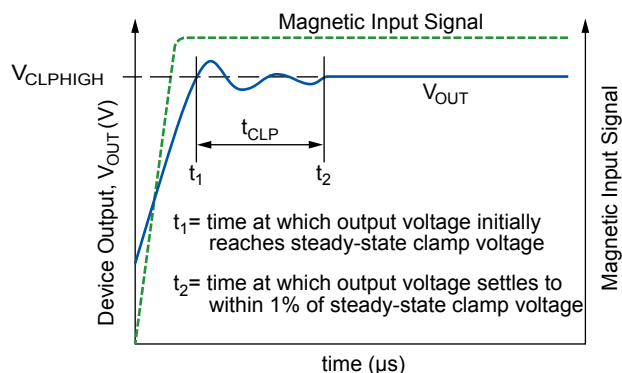


Figure 2: Definition of Delay to Clamp,  $t_{CLP}$

**Quiescent Voltage Output.** In the quiescent state (no significant magnetic field:  $B = 0$  G), the output,  $V_{OUT(Q)}$ , is at a constant ratio to the supply voltage,  $V_{CC}$ , across the entire operating ranges of  $V_{CC}$  and Operating Ambient Temperature,  $T_A$ .

**Quiescent Voltage Output Drift Across Temperature Range.** Due to internal component tolerances and thermal considerations, the Quiescent Voltage Output,  $V_{OUT(Q)}$ , may drift due to temperature changes within the Operating Ambient Temperature,  $T_A$ . For purposes of specification, the Quiescent Voltage Output Drift Across Temperature Range,  $\Delta V_{OUT(Q)}$  (mV), is defined as:

$$\Delta V_{OUT(Q)} = V_{OUT(Q)(T_A)} - V_{OUT(Q)(25^\circ\text{C})} \quad (1)$$

**Sensitivity.** The amount of the output voltage change is proportional to the magnitude and polarity of the magnetic field applied. This proportionality is specified as the magnetic sensitivity, Sens (mV/G), of the device and is defined as:

$$\text{Sens} = \frac{V_{OUT(B+)} - V_{OUT(B-)}}{(B+) - (B-)} \quad (2)$$

where  $B+$  is the magnetic flux density in a positive field (south polarity) and  $B-$  is the magnetic flux density in a negative field (north polarity).

**Sensitivity Temperature Coefficient.** The device sensitivity changes as temperature changes, with respect to its Sensitivity Temperature Coefficient,  $TC_{SENS}$ .  $TC_{SENS}$  is programmed at  $150^\circ\text{C}$  (L temperature device) or at  $125^\circ\text{C}$  (K temperature device), and calculated relative to the baseline sensitivity programming temperature of  $25^\circ\text{C}$ .  $TC_{SENS}$  is defined as:

$$TC_{SENS} = \left( \frac{\text{Sens}_{T2} - \text{Sens}_{T1}}{\text{Sens}_{T1}} \times 100 \right) \left( \frac{1}{T2 - T1} \right) \quad (\%/^\circ\text{C}) \quad (3)$$

where  $T1$  is the baseline Sens programming temperature of  $25^\circ\text{C}$ , and  $T2$  is the  $TC_{SENS}$  programming temperature of  $150^\circ\text{C}$  (L temperature device) or  $125^\circ\text{C}$  (K temperature device).

The ideal value of Sens across the full ambient temperature range,  $\text{Sens}_{IDEAL(T_A)}$ , is defined as:

$$\text{Sens}_{IDEAL(T_A)} = \text{Sens}_{T1} \times [100 (\%) + TC_{SENS} (T_A - T1)] \quad (4)$$

**Sensitivity Drift Across Temperature Range.** Second-order sensitivity temperature coefficient effects cause the magnetic sensitivity, Sens, to drift from its ideal value across the operating ambient temperature range,  $T_A$ . For purposes of speci-

ation, the Sensitivity Drift Across Temperature Range,  $\Delta\text{Sens}_{\text{TC}}$ , is defined as:

$$\Delta\text{Sens}_{\text{TC}} = \frac{\text{Sens}_{\text{TA}} - \text{Sens}_{\text{IDEAL(TA)}}}{\text{Sens}_{\text{IDEAL(TA)}}} \times 100 \quad (\%) \quad (5)$$

**Sensitivity Drift Due to Package Hysteresis.** Package stress and relaxation can cause the device sensitivity at  $T_A = 25^\circ\text{C}$  to change during and after temperature cycling. This change in sensitivity follows a hysteresis curve. For purposes of specification, the Sensitivity Drift Due to Package Hysteresis,  $\Delta\text{Sens}_{\text{PKG}}$ , is defined as:

$$\Delta\text{Sens}_{\text{PKG}} = \frac{\text{Sens}_{(25^\circ\text{C})(2)} - \text{Sens}_{(25^\circ\text{C})(1)}}{\text{Sens}_{(25^\circ\text{C})(1)}} \times 100 \quad (\%) \quad (6)$$

where  $\text{Sens}_{(25^\circ\text{C})(1)}$  is the programmed value of sensitivity at  $T_A = 25^\circ\text{C}$ , and  $\text{Sens}_{(25^\circ\text{C})(2)}$  is the value of sensitivity at  $T_A = 25^\circ\text{C}$  after temperature cycling  $T_A$  up to  $150^\circ\text{C}$  (L temperature device) or  $125^\circ\text{C}$  (K temperature device), down to  $-40^\circ\text{C}$ , and back up to  $25^\circ\text{C}$ .

**Linearity Sensitivity Error.** The A1308 and A1309 are designed to provide linear output in response to a ramping applied magnetic field. Consider two magnetic fields, B1 and B2. Ideally, the sensitivity of a device is the same for both fields, for a given supply voltage and temperature. Linearity error is present when there is a difference between the sensitivities measured at B1 and B2.

Linearity Sensitivity Error,  $\text{Lin}_{\text{ERR}}$ , is calculated separately for positive ( $\text{Lin}_{\text{ERR}+}$ ) and negative ( $\text{Lin}_{\text{ERR}-}$ ) applied magnetic fields.  $\text{Lin}_{\text{ERR}}$  (%) is measured and defined as:

$$\text{Lin}_{\text{ERR}+} = \left(1 - \frac{\text{Sens}_{(B+)(2)}}{\text{Sens}_{(B+)(1)}}\right) \times 100 \quad (\%) \quad (7)$$

$$\text{Lin}_{\text{ERR}-} = \left(1 - \frac{\text{Sens}_{(B-)(2)}}{\text{Sens}_{(B-)(1)}}\right) \times 100 \quad (\%)$$

where:

$$\text{Sens}_{\text{Bx}} = \frac{|V_{\text{OUT(Bx)}} - V_{\text{OUT(Q)}}|}{B_x} \quad (8)$$

and Bx are positive and negative magnetic fields, with respect to the quiescent voltage output, such that

$$|B_{(+)2}| > |B_{(+)1}| \text{ and } |B_{(-)2}| > |B_{(-)1}|$$

The effective linearity error is:

$$\text{Lin}_{\text{ERR}} = \max(|\text{Lin}_{\text{ERR}+}|, |\text{Lin}_{\text{ERR}-}|) \quad (9)$$

The output voltage clamps,  $V_{\text{CLPHIGH}}$  and  $V_{\text{CLPLOW}}$ , limit the operating magnetic range of the applied field in which the device provides a linear output. The maximum positive and negative applied magnetic fields in the operating range can be calculated:

$$|B_{\text{MAX}(+)}| = \frac{V_{\text{CLPHIGH}} - V_{\text{OUT(Q)}}}{\text{Sens}} \quad (10)$$

$$|B_{\text{MAX}(-)}| = \frac{V_{\text{OUT(Q)}} - V_{\text{CLPLOW}}}{\text{Sens}}$$

**Symmetry Sensitivity Error.** The magnetic sensitivity of the device is constant for any two applied magnetic fields of equal magnitude and opposite polarities. Symmetry error,  $\text{Sym}_{\text{ERR}}$  (%), is measured and defined as:

$$\text{Sym}_{\text{ERR}} = \left(1 - \frac{\text{Sens}_{(B+)}}{\text{Sens}_{(B-)}}\right) \times 100 \quad (\%) \quad (11)$$

where  $\text{Sens}_{\text{Bx}}$  is as defined in equation 10, and B+ and B- are positive and negative magnetic fields such that  $|B+| = |B-|$ .

**Ratiometry Error.** The A1308 and A1309 provide ratiometric output. This means that the Quiescent Voltage Output,  $V_{\text{OUT(Q)}}$ , magnetic sensitivity, Sens, and clamp voltages,  $V_{\text{CLPHIGH}}$  and  $V_{\text{CLPLOW}}$ , are proportional to the supply voltage,  $V_{\text{CC}}$ . In other words, when the supply voltage increases or decreases by a certain percentage, each characteristic also increases or decreases by the same percentage. Error is the difference between the measured change in the supply voltage relative to 5 V and the measured change in each characteristic.

The ratiometric error in quiescent voltage output,  $\text{Rat}_{V_{\text{OUT(Q)}}}$  (%), for a given supply voltage,  $V_{\text{CC}}$ , is defined as:

$$\text{Rat}_{V_{\text{OUT(Q)}}} = \left(1 - \frac{V_{\text{OUT(Q)(VCC)}} / V_{\text{OUT(Q)(5V)}}}{V_{\text{CC}} / 5 \text{ (V)}}\right) \times 100 \quad (\%) \quad (12)$$

The ratiometric error in magnetic sensitivity,  $\text{Rat}_{\text{Sens}}$  (%), for a given supply voltage,  $V_{\text{CC}}$ , is defined as:

$$\text{Rat}_{\text{Sens}} = \left(1 - \frac{\text{Sens}_{(VCC)} / \text{Sens}_{(5V)}}{V_{\text{CC}} / 5 \text{ (V)}}\right) \times 100 \quad (\%) \quad (13)$$

The ratiometric error in the clamp voltages,  $\text{Rat}_{V_{\text{OUTCLP}}}$  (%), for a given supply voltage,  $V_{\text{CC}}$ , is defined as:

$$\text{Rat}_{V_{\text{OUTCLP}}} = \left(1 - \frac{V_{\text{CLP(VCC)}} / V_{\text{CLP(5V)}}}{V_{\text{CC}} / 5 \text{ (V)}}\right) \times 100 \quad (\%) \quad (14)$$

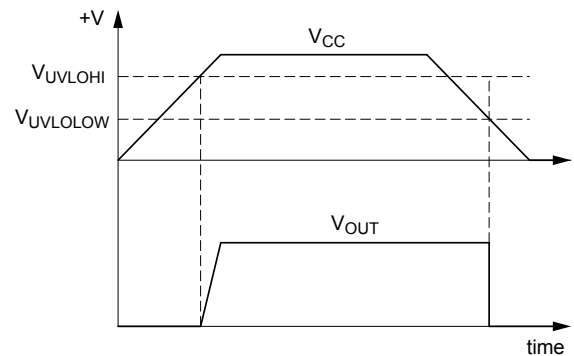
where  $V_{\text{CLP}}$  is either  $V_{\text{CLPHIGH}}$  or  $V_{\text{CLPLOW}}$ .

**Undervoltage Lockout.** The A1308 and A1309 provide an undervoltage lockout feature which ensures that the device outputs a  $V_{OUT}$  signal only when  $V_{CC}$  is above certain thresholds. The undervoltage lockout feature provides a hysteresis of operation to eliminate indeterminate output states.

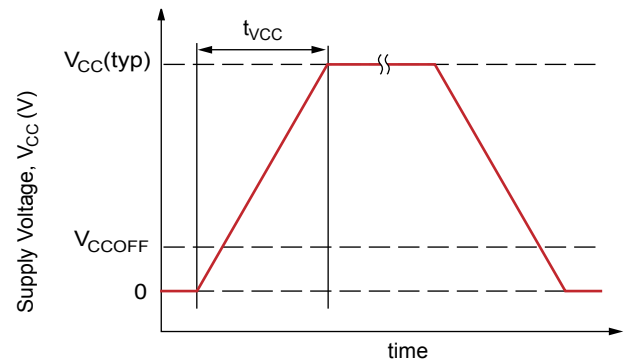
The output of the A1308 and A1309 is held low (GND) until  $V_{CC}$  exceeds  $V_{UVLOHI}$ . After  $V_{CC}$  exceeds  $V_{UVLOHI}$ , the device  $V_{OUT}$  output is enabled, providing a ratiometric output voltage that is proportional to the input magnetic signal and  $V_{CC}$ . If  $V_{CC}$  should drop back down below  $V_{UVLOLO}$  after the device is powered up, the output would be pulled low (see Figure 3) until  $V_{UVLOHI}$  is reached again and  $V_{OUT}$  would be reenabled.

**$V_{CC}$  Ramp Time.** The time taken for  $V_{CC}$  to ramp from 0 V to  $V_{CC}(typ)$ , 5 V (see Figure 4).

**$V_{CC}$  Off Level.** For applications in which the  $V_{CC}$  pin of the A1308 or A1309 is being power-cycled (for example using a multiplexer to toggle the part on and off), the specification of  $V_{CC}$  Off Level,  $V_{CCOFF}$ , determines how high a  $V_{CC}$  off voltage can be tolerated while still ensuring proper operation and startup of the device (see Figure 4).

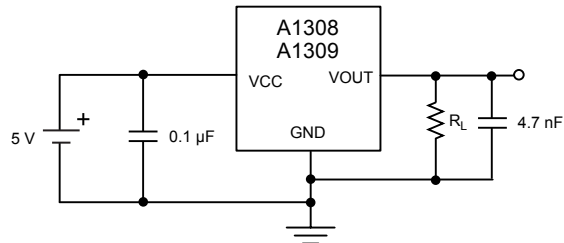


**Figure 3: Definition of Undervoltage Lockout**



**Figure 4: Definition of  $V_{CC}$  Ramp Time,  $t_{VCC}$**

### APPLICATION INFORMATION

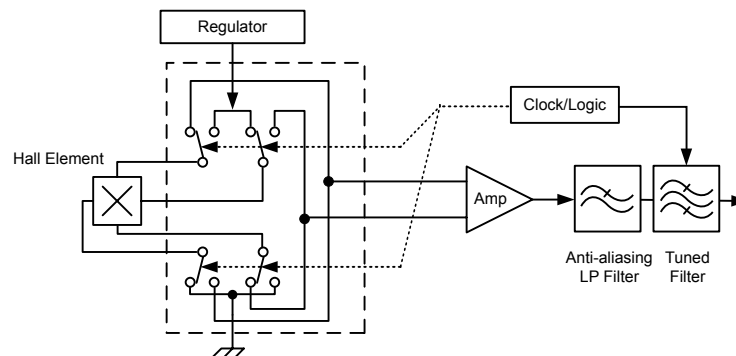


**Figure 6: Typical Application Circuit**

#### Chopper Stabilization Technique

When using Hall-effect technology, a limiting factor for switch point accuracy is the small signal voltage developed across the Hall element. This voltage is disproportionately small relative to the offset that can be produced at the output of the Hall sensor IC. This makes it difficult to process the signal while maintaining an accurate, reliable output over the specified operating temperature and voltage ranges. Chopper stabilization is a unique approach used to minimize Hall offset on the chip. Allegro employs a technique to remove key sources of the output drift induced by thermal and mechanical stresses. This offset reduction technique is based on a signal modulation-demodulation process. The undesired offset signal is separated from the magnetic field-induced signal in the frequency domain, through modulation. The subsequent demodulation acts as a modulation process for the offset, causing the magnetic field-induced signal to recover its original spectrum at baseband, while the DC offset becomes a

high-frequency signal. The magnetic-sourced signal then can pass through a low-pass filter, while the modulated DC offset is suppressed. In addition to the removal of the thermal and mechanical stress-related offset, this novel technique also reduces the amount of thermal noise in the Hall sensor IC while completely removing the modulated residue resulting from the chopper operation. The chopper stabilization technique uses a high-frequency sampling clock. For demodulation process, a sample-and-hold technique is used. This high-frequency operation allows a greater sampling rate, which results in higher accuracy and faster signal-processing capability. This approach desensitizes the chip to the effects of thermal and mechanical stresses and produces devices that have extremely stable quiescent Hall output voltages and precise recoverability after temperature cycling. This technique is made possible through the use of a BiCMOS process, which allows the use of low-offset, low-noise amplifiers in combination with high-density logic integration and sample-and-hold circuits.



**Figure 5: Chopper Stabilization Technique**

# A1308 and A1309

# Linear Hall-Effect Sensor ICs with Analog Output Available in a Miniature, Low-Profile Surface-Mount Package

## For Reference Only – Not for Tooling Use

(Reference Allegro DWG-0000628, Rev. 1)

NOT TO SCALE

Dimensions in millimeters

Dimensions exclusive of mold flash, gate burrs, and dambar protrusions  
Exact case and lead configuration at supplier discretion within limits shown

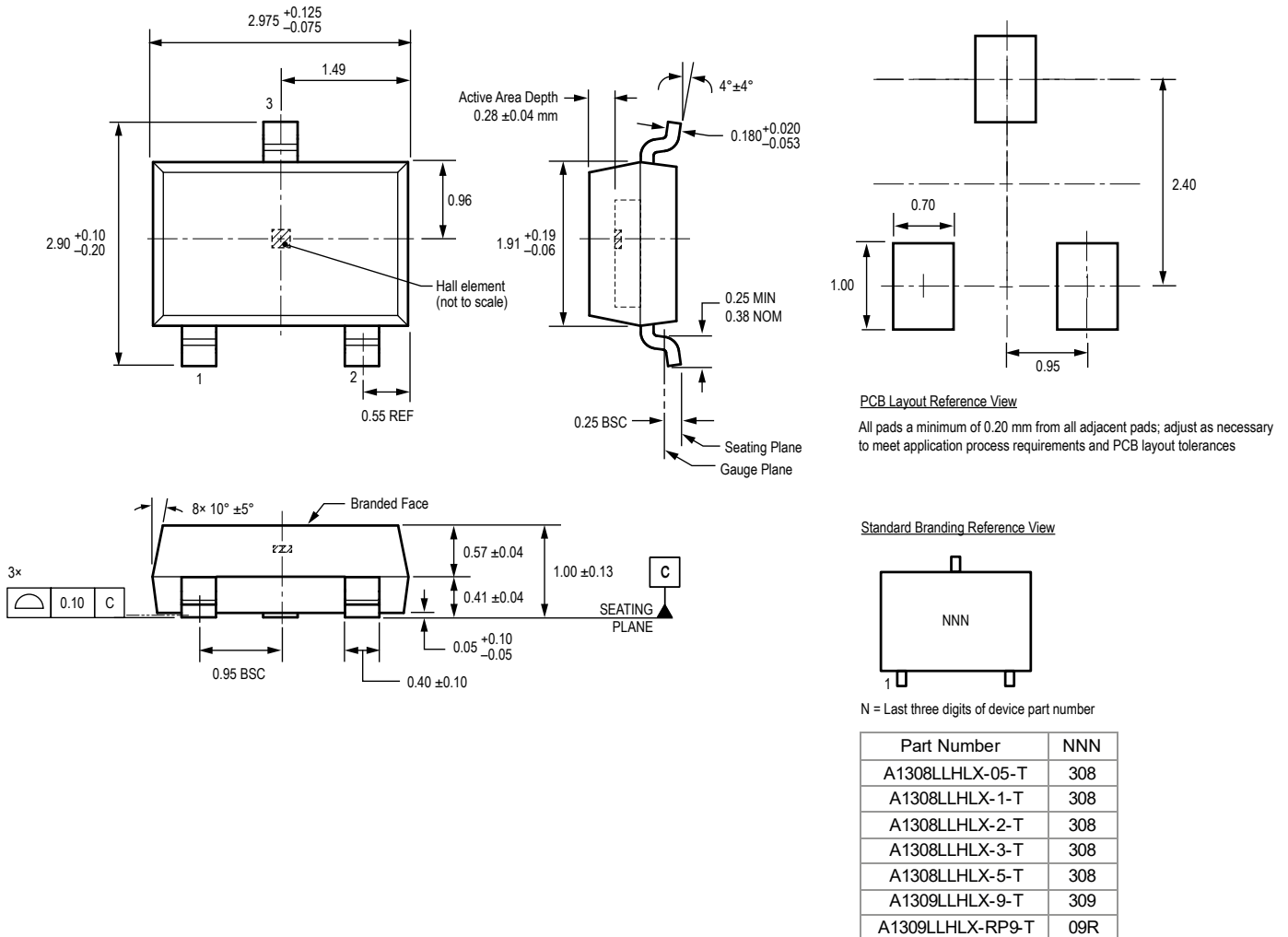


Figure 7: Package LH, 3-Pin (SOT-23W)

# A1308 and A1309

# Linear Hall-Effect Sensor ICs with Analog Output Available in a Miniature, Low-Profile Surface-Mount Package

**Figure 8: Package UA, 3-Pin SIP, Matrix Style**

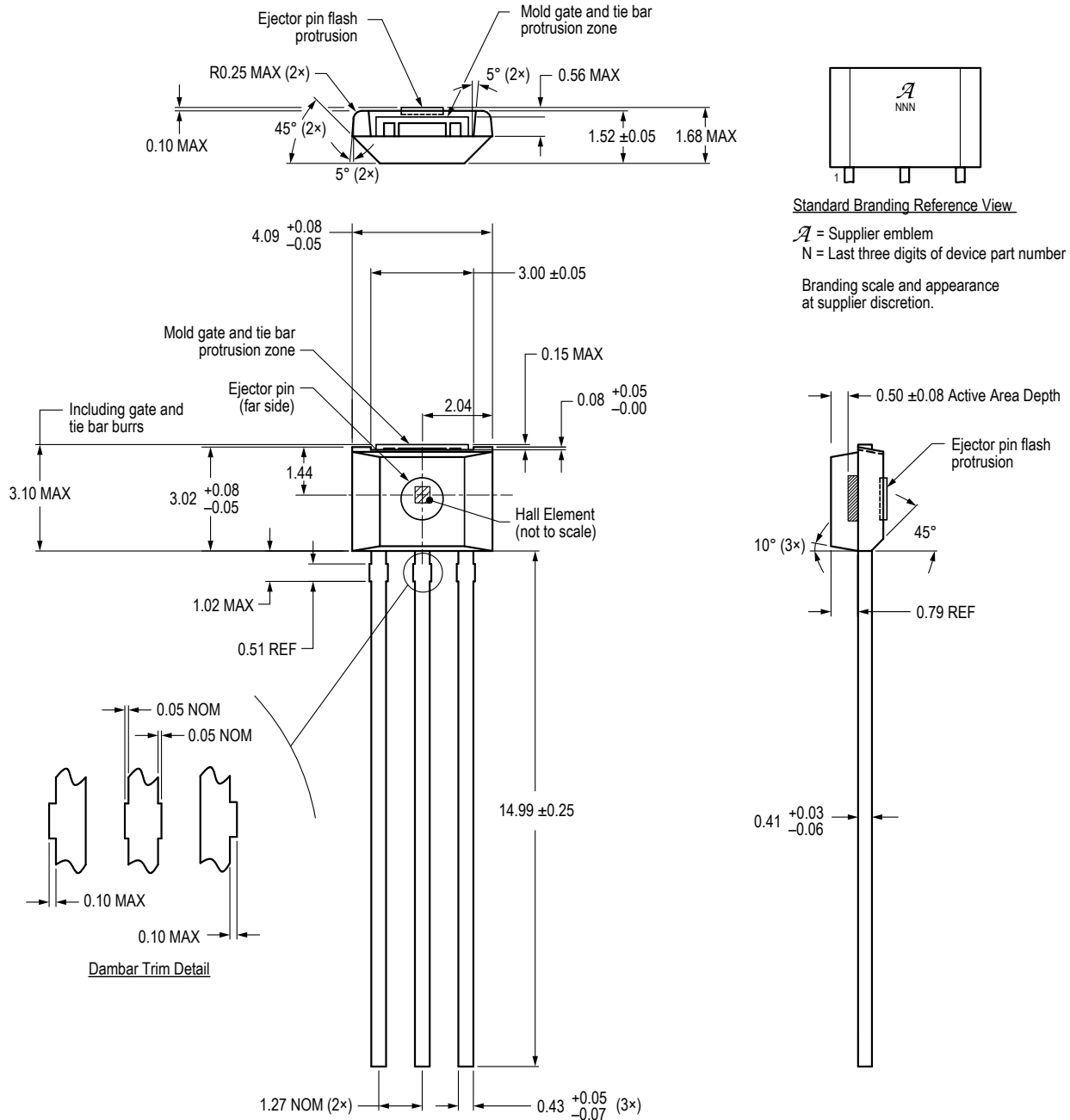
**For Reference Only – Not For Tooling Use**

(Reference DWG-0000404, Rev. 1)

NOT TO SCALE

Dimensions in millimeters

Exact case and lead configuration at supplier discretion within limits shown



# A1308 and A1309

## Linear Hall-Effect Sensor ICs with Analog Output Available in a Miniature, Low-Profile Surface-Mount Package

### Revision History

Number	Date	Description
–	June 27, 2014	Initial release
1	June 27, 2014	Updated product offerings
2	November 13, 2015	Updated product offerings
3	March 30, 2016	Updated product offerings
4	April 19, 2016	Updated product offerings
5	September 2, 2016	Updated product offerings
6	December 9, 2016	Updated product offerings
7	January 4, 2017	Updated product offerings
8	June 6, 2017	Updated product offerings and Figure 3
9	November 14, 2018	Added A1309LUA-2-T and A1308LUA-9-T part options
10	September 30, 2019	Added A1308KUA-2-T part option; updated LH and UA package drawings and other minor editorial updates
11	February 20, 2020	Removed A1308LUA-9-T part option
12	February 17, 2022	Updated package drawings (pages 10-11)
13	July 24, 2023	Removed A1309LUA-2-T part option and added A1308-LUA-2-T part option (pages 2, 4-5)
14	April 23, 2026	Added AEC-Q100 qualification info (page 1)
15	May 28, 2026	Updated and reordered Operating Characteristics table to match Selection Guide (pages 4-5)

Copyright 2026, Allegro MicroSystems.

Allegro MicroSystems reserves the right to make, from time to time, such departures from the detail specifications as may be required to permit improvements in the performance, reliability, or manufacturability of its products. Before placing an order, the user is cautioned to verify that the information being relied upon is current.

Allegro's products are not to be used in any devices or systems, including but not limited to life support devices or systems, in which a failure of Allegro's product can reasonably be expected to cause bodily harm.

The information included herein is believed to be accurate and reliable. However, Allegro MicroSystems assumes no responsibility for its use; nor for any infringement of patents or other rights of third parties which may result from its use.

Copies of this document are considered uncontrolled documents.

For the latest version of this document, visit our website:

[www.allegromicro.com](http://www.allegromicro.com)