

N-channel 800 V, 1.3 Ω typ., 4.5 A MDmesh K5 Power MOSFET in a TO-220FP package

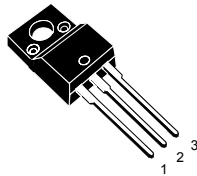

TO-220FP

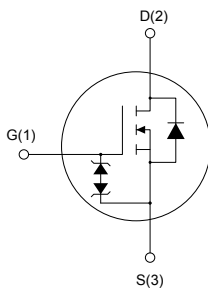

AM01476v1

Product status link
[STF6N80K5](#)
Product summary

Order code	STF6N80K5
Marking	6N80K5
Package	TO-220FP
Packing	Tube

Features

Order code	V_{DS}	$R_{DS(on)}$ max.	I_D
STF6N80K5	800 V	1.6 Ω	4.5 A

- Ultra-low gate charge
- Very low FoM (figure of merit)
- Zener-protected
- 100% avalanche tested

Applications

- Switching applications

Description

This very high voltage N-channel Power MOSFET is designed using MDmesh K5 technology based on an innovative proprietary vertical structure. The result is a dramatic reduction in on-resistance and ultra-low gate charge for applications requiring superior power density and high efficiency.

1 Electrical ratings

Table 1. Absolute maximum ratings

Symbol	Parameter	Value	Unit
V_{DS}	Drain-source voltage	800	V
V_{GS}	Gate-source voltage	±30	V
I_D	Drain current (continuous) at $T_C = 25\text{ °C}$	4.5	A
	Drain current (continuous) at $T_C = 100\text{ °C}$	2.8	
$I_{DM}^{(1)}$	Drain current (pulsed)	18	A
P_{TOT}	Total power dissipation at $T_C = 25\text{ °C}$	25	W
V_{ISO}	Insulation withstand voltage (RMS) from all three leads to external heat sink ($t = 1\text{ s}$; $T_C = 25\text{ °C}$)	2.5	kV
$dv/dt^{(2)}$	Peak diode recovery voltage slope	4.5	V/ns
$dv/dt^{(3)}$	MOSFET dv/dt ruggedness	50	V/ns
T_{stg}	Storage temperature range	-55 to 150	°C
T_J	Operating junction temperature range		°C

1. Pulse width is limited by safe operating area.
2. $I_{SD} \leq 4.5\text{ A}$, $di/dt = 100\text{ A}/\mu\text{s}$, $V_{DS}(\text{peak}) < V_{(BR)DSS}$.
3. $V_{DD} \leq 640\text{ V}$.

Table 2. Thermal data

Symbol	Parameter	Value	Unit
R_{thJC}	Thermal resistance, junction-to-case	5	°C/W
R_{thJA}	Thermal resistance, junction-to-ambient	62.5	°C/W

Table 3. Avalanche characteristics

Symbol	Parameter	Value	Unit
I_{AR}	Avalanche current, repetitive or non-repetitive (pulse width limited by T_J max.)	1.5	A
E_{AS}	Single pulse avalanche energy (starting $T_J = 25\text{ °C}$, $I_D = I_{AR}$, $V_{DD} = 50\text{ V}$)	85	mJ

2 Electrical characteristics

$T_C = 25\text{ °C}$ unless otherwise specified.

Table 4. Static

Symbol	Parameter	Test conditions	Min.	Typ.	Max.	Unit
$V_{(BR)DSS}$	Drain-source breakdown voltage	$V_{GS} = 0\text{ V}$, $I_D = 1\text{ mA}$	800	-	-	V
I_{DSS}	Zero gate voltage drain current	$V_{GS} = 0\text{ V}$, $V_{DS} = 800\text{ V}$	-	-	1	μA
		$V_{GS} = 0\text{ V}$, $V_{DS} = 800\text{ V}$, $T_C = 125\text{ °C}^{(1)}$	-	-	50	
I_{GSS}	Gate-body leakage current	$V_{DS} = 0\text{ V}$, $V_{GS} = \pm 20\text{ V}$	-	-	± 10	μA
$V_{GS(th)}$	Gate threshold voltage	$V_{DS} = V_{GS}$, $I_D = 100\text{ }\mu\text{A}$	3	4	5	V
$R_{DS(on)}$	Static drain-source on-resistance	$V_{GS} = 10\text{ V}$, $I_D = 2\text{ A}$	-	1.3	1.6	Ω

1. Specified by design, not tested in production.

Table 5. Dynamic

Symbol	Parameter	Test conditions	Min.	Typ.	Max.	Unit
C_{iss}	Input capacitance	$V_{DS} = 100\text{ V}$, $f = 1\text{ MHz}$, $V_{GS} = 0\text{ V}$	-	270	-	pF
C_{oss}	Output capacitance		-	25	-	pF
C_{rss}	Reverse transfer capacitance		-	0.7	-	pF
$C_{o(tr)}^{(1)}$	Equivalent output capacitance time related	$V_{DS} = 0\text{ to }640\text{ V}$, $V_{GS} = 0\text{ V}$	-	38	-	pF
$C_{o(er)}^{(2)}$	Equivalent output capacitance energy related		-	16	-	pF
R_g	Intrinsic gate resistance	$f = 1\text{ MHz}$, $I_D = 0\text{ A}$	-	7.5	-	Ω
Q_g	Total gate charge	$V_{DD} = 640\text{ V}$, $I_D = 4.5\text{ A}$, $V_{GS} = 0\text{ to }10\text{ V}$ (see the Figure 14. Test circuit for gate charge behavior)	-	13	-	nC
Q_{gs}	Gate-source charge		-	2.1	-	nC
Q_{gd}	Gate-drain charge		-	9.6	-	nC

1. $C_{o(tr)}$ is a constant capacitance value that gives the same charging time as C_{oss} while V_{DS} is rising from 0 to 80% V_{DSS} .

2. $C_{o(er)}$ is a constant capacitance value that gives the same stored energy as C_{oss} while V_{DS} is rising from 0 to 80% V_{DSS} .

Table 6. Switching times

Symbol	Parameter	Test conditions	Min.	Typ.	Max.	Unit
$t_{d(on)}$	Turn-on delay time	$V_{DD} = 400\text{ V}$, $I_D = 2.25\text{ A}$, $R_G = 4.7\text{ }\Omega$, $V_{GS} = 10\text{ V}$	-	16	-	ns
t_r	Rise time		-	7.5	-	ns
$t_{d(off)}$	Turn-off delay time	(see the Figure 13. Test circuit for resistive load switching times and Figure 18. Switching time waveform)	-	28.5	-	ns
t_f	Fall time		-	16	-	ns

Table 7. Source-drain diode

Symbol	Parameter	Test conditions	Min.	Typ.	Max.	Unit
I_{SD}	Source-drain current		-	-	4.5	A
$I_{SDM}^{(1)}$	Source-drain current (pulsed)		-	-	18	A
$V_{SD}^{(2)}$	Forward on voltage	$V_{GS} = 0\text{ V}$, $I_{SD} = 4.5\text{ A}$	-	-	1.5	V
t_{rr}	Reverse recovery time	$I_{SD} = 4.5\text{ A}$, $di/dt = 100\text{ A}/\mu\text{s}$,	-	280	-	ns
Q_{rr}	Reverse recovery charge	$V_{DD} = 60\text{ V}$	-	2.2	-	μC
I_{RRM}	Reverse recovery current	(see the Figure 15. Test circuit for inductive load switching and diode recovery times)	-	15.5	-	A
t_{rr}	Reverse recovery time	$I_{SD} = 4.5\text{ A}$, $di/dt = 100\text{ A}/\mu\text{s}$,	-	450	-	ns
Q_{rr}	Reverse recovery charge	$V_{DD} = 60\text{ V}$, $T_J = 150\text{ }^\circ\text{C}$	-	3.15	-	μC
I_{RRM}	Reverse recovery current	(see the Figure 15. Test circuit for inductive load switching and diode recovery times)	-	14	-	A

1. Pulse width is limited by safe operating area.
2. Pulse test: pulse duration = 300 μs , duty cycle 1.5%.

2.1 Electrical characteristics (curves)

Figure 1. Safe operating area

Figure 2. Normalized transient thermal impedance

Figure 3. Typical output characteristics

Figure 4. Typical transfer characteristics

Figure 5. Typical gate charge characteristics

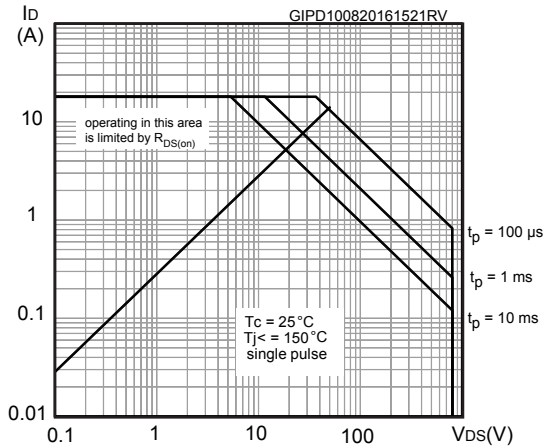
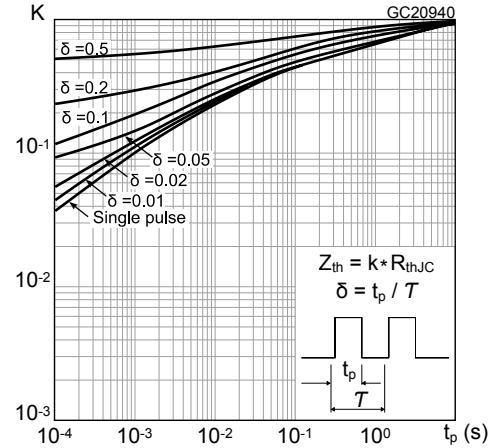
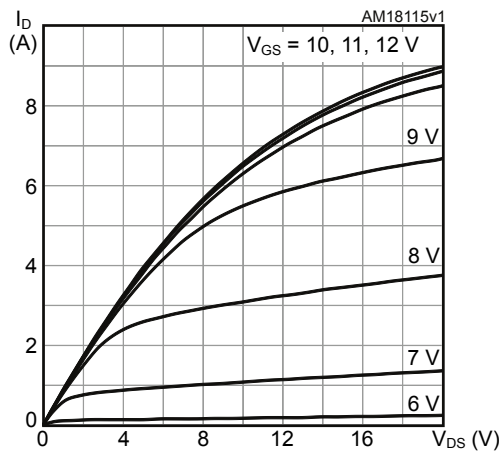
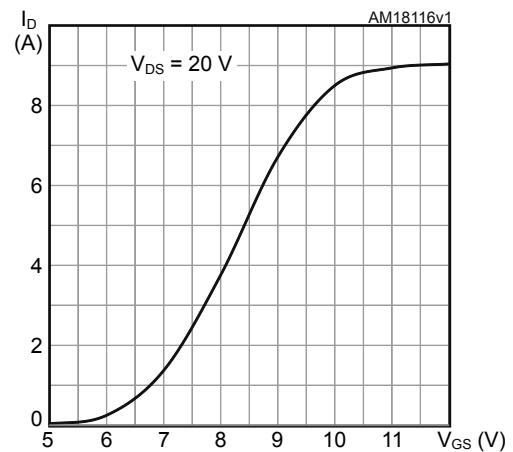
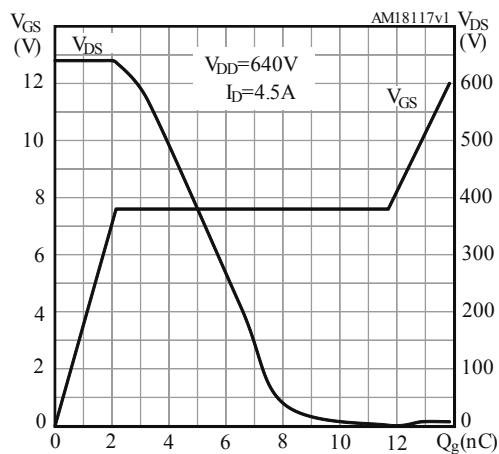
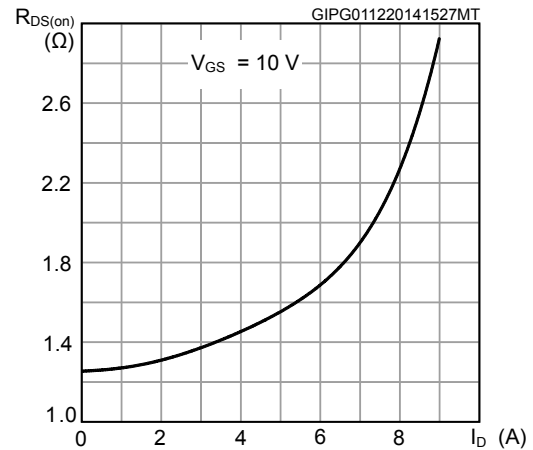
Figure 6. Typical drain-source on-resistance

Figure 7. Typical capacitance characteristics

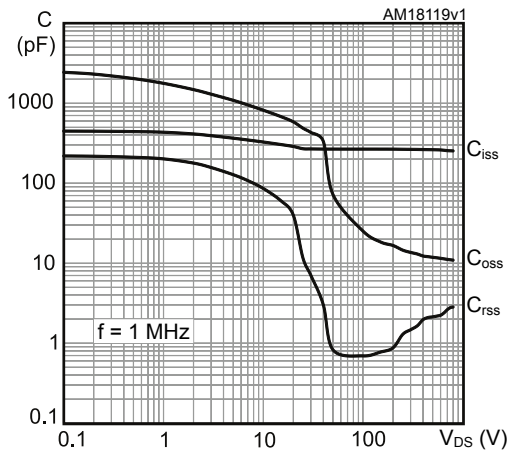

Figure 8. Typical output capacitance stored energy

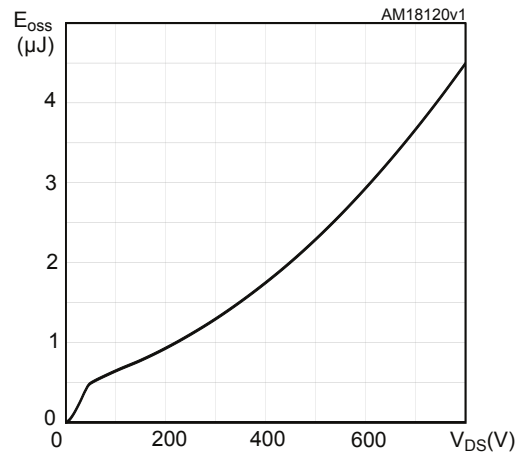

Figure 9. Normalized gate threshold vs temperature

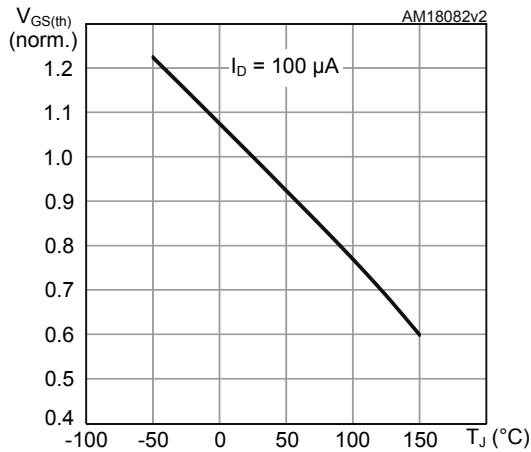

Figure 10. Normalized on-resistance vs temperature

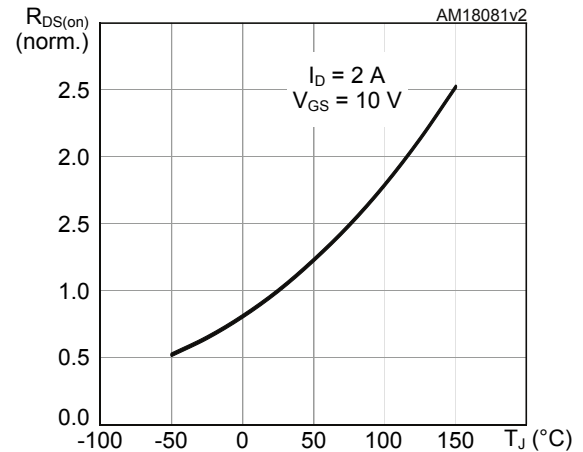

Figure 11. Normalized breakdown voltage vs temperature

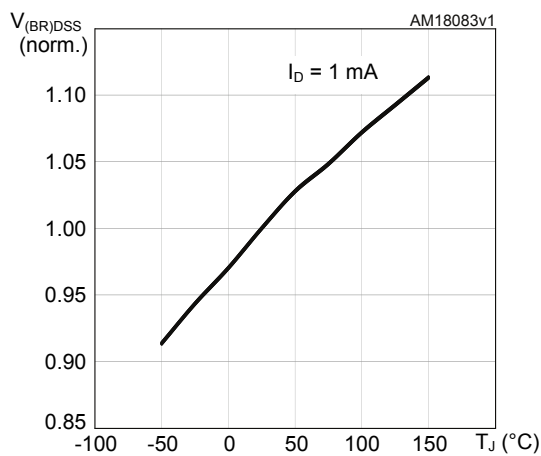
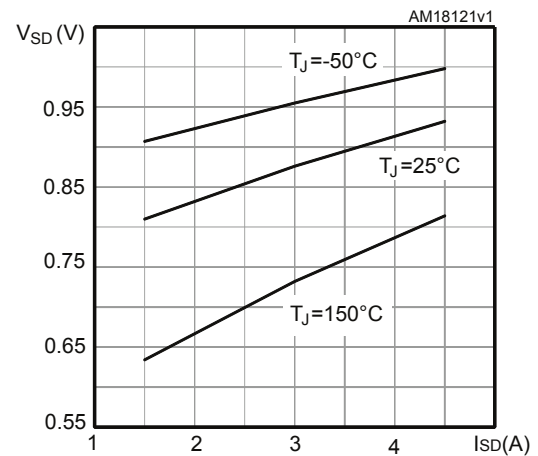

Figure 12. Typical reverse diode forward characteristics



3 Test circuits

Figure 13. Test circuit for resistive load switching times

AM01468v1

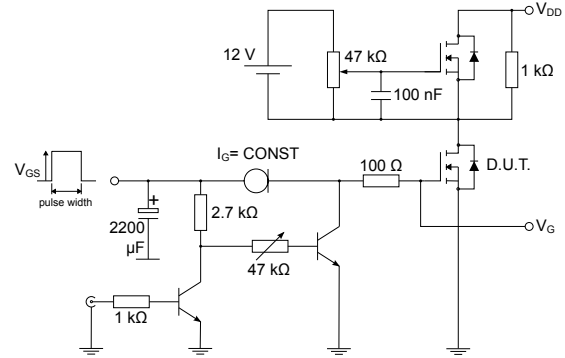
Figure 14. Test circuit for gate charge behavior

AM01469v1

Figure 15. Test circuit for inductive load switching and diode recovery times

AM01470v1

Figure 16. Unclamped inductive load test circuit

AM01471v1

Figure 17. Unclamped inductive waveform

AM01472v1

Figure 18. Switching time waveform



AM01473v1

4 Package information

To meet environmental requirements, ST offers these devices in different grades of **ECOPACK** packages, depending on their level of environmental compliance. ECOPACK specifications, grade definitions, and product status are available at: www.st.com. ECOPACK is an ST trademark.

4.1 TO-220FP type B package information

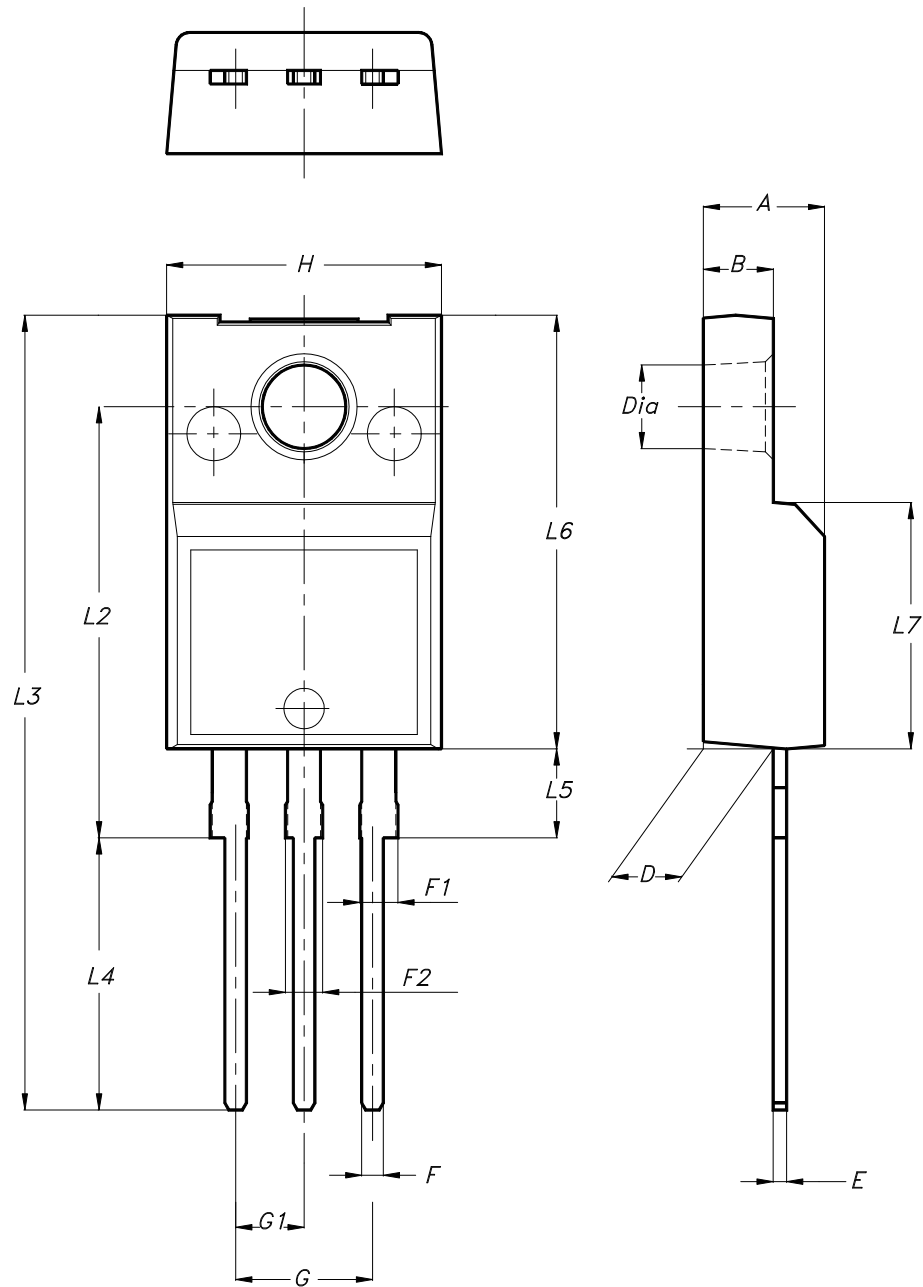
Figure 19. TO-220FP type B package outline



7012510_B_rev.14

Table 8. TO-220FP type B package mechanical data

Dim.	mm		
	Min.	Typ.	Max.
A	4.40		4.60
B	2.50		2.70
D	2.50		2.75
E	0.45		0.70
F	0.75		1.00
F1	1.15		1.70
F2	1.15		1.70
G	4.95		5.20
G1	2.40		2.70
H	10.00		10.40
L2		16.00	
L3	28.60		30.60
L4	9.80		10.60
L5	2.90		3.60
L6	15.90		16.40
L7	9.00		9.30
Dia	3.00		3.20

Revision history

Table 9. Document revision history

Date	Revision	Changes
28-May-2013	1	First release.
05-Mar-2014	2	<p>Datasheet status promoted from preliminary data to production data.</p> <p>Added: I2PAKFP package.</p> <p>Modified: E_{AS} value in <i>Table 2</i>.</p> <p>Added: MOSFET dv/dt ruggedness test condition and <i>note 4</i> in <i>Table 2</i>.</p> <p>Modified: R_G value in <i>Table 5</i>.</p> <p>Modified: the entire typical values in <i>Table 5</i>, <i>6</i> and <i>7</i>.</p> <p>Added: <i>Section 2.1: Electrical characteristics (curves)</i>.</p> <p>Minor text changes.</p>
05-Dec-2014	3	<p>Updated title, features and description in cover page.</p> <p>Updated <i>Section 2.1: Electrical characteristics (curves)</i> and <i>Section 4: Package information</i>.</p> <p>Minor text changes.</p>
06-Sep-2016	4	<p>Updated <i>Table 2: Absolute maximum ratings</i>, <i>Table 4: On/off states</i>, <i>Table 5: Dynamic</i>, <i>Table 6: Switching times</i> and <i>Table 7: Source drain diode</i>.</p> <p>Updated <i>Figure 2: Safe operating area</i> and <i>Figure 3: Thermal impedance</i>.</p> <p>Minor text changes.</p>
27-Mar-2026	5	<p>Removed order code STF16N80K5.</p> <p>Updated <i>Section 4: Package information</i>.</p> <p>Minor text changes.</p>

Contents

1	Electrical ratings	2
2	Electrical characteristics	3
2.1	Electrical characteristics (curves)	5
3	Test circuits	7
4	Package information	8
4.1	TO-220FP type B package information	8
	Revision history	10

IMPORTANT NOTICE – READ CAREFULLY

STMicroelectronics NV and its subsidiaries (“ST”) reserve the right to make changes, corrections, enhancements, modifications, and improvements to ST products and/or to this document at any time without notice.

In the event of any conflict between the provisions of this document and the provisions of any contractual arrangement in force between the purchasers and ST, the provisions of such contractual arrangement shall prevail.

The purchasers should obtain the latest relevant information on ST products before placing orders. ST products are sold pursuant to ST’s terms and conditions of sale in place at the time of order acknowledgment.

The purchasers are solely responsible for the choice, selection, and use of ST products and ST assumes no liability for application assistance or the design of the purchasers’ products.

No license, express or implied, to any intellectual property right is granted by ST herein.

Resale of ST products with provisions different from the information set forth herein shall void any warranty granted by ST for such product.

If the purchasers identify an ST product that meets their functional and performance requirements but that is not designated for the purchasers’ market segment, the purchasers shall contact ST for more information.

ST and the ST logo are trademarks of ST. For additional information about ST trademarks, refer to www.st.com/trademarks. All other product or service names are the property of their respective owners.

Information in this document supersedes and replaces information previously supplied in any prior versions of this document.

© 2026 STMicroelectronics – All rights reserved